

"TRADER" SERVICE SHEET  
**1273**

# ROBERTS R66

2-band A.C./All-dry Portable Superhet

### GENERAL NOTES

**Switches.**—S1-S5 are the band switches, and S6(M)-S12(B) are the mains/battery change-over switches ganged in two rotary units beneath the chassis. These units are indicated in the underside illustration of the chassis, and shown in detail in the diagram in column 2 overleaf.

Switches S1, S3 and S5 close for M.W. operation and switches S2, S4 close for L.W. operation. Switches with the suffix (M) close for mains operation and those with the suffix (B) close for battery operation. From the fully anti-clockwise setting of the control knob, the switch positions are L.W. (batt.); M.W. (batt.); off; M.W. (mains); L.W. (mains).

**Batteries.**—Those recommended by the makers are: L.T., Ever Ready AD35 rated at 1.5V; H.T., Ever Ready B126 rated at 90V. A standard 3-pin plug is used for H.T. battery connection, and a standard 2-pin plug is used for L.T. battery connection.

(Continued col. 1 overleaf)

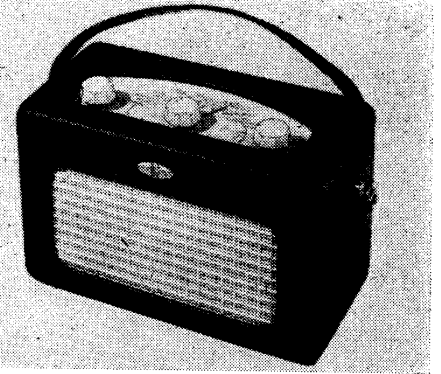

Appearance of the Roberts R66

**E**MPLYING a ferrite rod internal aerial, the Roberts R66 is a 2-band 4-valve (plus two metal rectifiers) portable, designed to operate from all-dry batteries or A.C. mains of 200-250 V. The wavebands covered are 182-580m and 900-2,000m.

Release date and original price: April, 1956, £13 19s. 9d. Batteries and purchase tax extra.

### CIRCUIT DESCRIPTION

Ferrite rod internal aerial coils L1 (M.W.) and L2 (L.W.) are tuned by C3 and precede heptode valve V1 which operates as frequency changer with electron coupling.

Oscillator grid coils L5 (M.W.) and L6 (L.W.) are tuned by C9. Parallel trimming by C10 (M.W.) and C10, C12 (L.W.); series tracking by C11 (M.W.) and C13 (L.W.). Reaction coupling from oscillator anode via L7 (M.W.) and L8 (L.W.).

Second valve V2 is a variable-mu R.F. pentode operating as intermediate frequency amplifier with tuned transformer couplings L3, L4 and L9, L10.

#### Intermediate frequency 470 kc/s.

Diode signal detector is part of diode pentode valve V3. Audio frequency component in its rectified output is developed across load resistor R6 and is passed via C20, volume control R8, and C21 to V3 pentode section which operates as A.F. amplifier. I.F. filtering by C19 and C24.

D.C. potential developed across R6 is fed back as bias to V1 and V2 giving automatic gain control. Resistance-capacitance coupling by R11, C23, R12 between V3 and pentode output valve V4. Grid bias is developed across R13 in the H.T. negative lead to chassis.

For mains operation switches S6(M), S7(M), S9(M) and S10(M) close, and H.T. current is supplied by half-wave metal rectifier MR1. Smoothing by R14 and electrolytic capacitors C27, C28. L.T. current is supplied by full-wave metal rectifier MR2, and is smoothed by R15, R16 and electrolytic capacitors C29, C30, C31. For battery operation, switches S8(B), S11(B) and S12(B) close and the (M) switches open.

### COMPONENT VALUES AND LOCATIONS

Capacitors				Resistors				Other Components*			
C1	60pF	C1	20μF	R1	1MΩ	D3	L1	0.65	C1		
C2	30pF	C1	0.001μF	R2	120kΩ	D3	L2	8.0	A1		
C3	523pF	F3	40μF	R3	27kΩ	D3	L3	10.6	C1		
C4	100pF	D3	40μF	R4	33kΩ	D3	L4	10.6	C1		
C5	0.01μF	D3	2,500μF	R5	39kΩ	E3	L5	2.3	C2		
C6	100pF	C2	2,500μF	R6	1MΩ	F3	L6	7.5	C2		
C7	100pF	C2	2,500μF	R7	2.2MΩ	F3	L7	2.0	C2		
C8	100pF	D3		R8	500kΩ	G3	L8	5.0	C2		
C9	523pF	F3		R9	10MΩ	G3	L9	10.6	A1		
C10	30pF	C1		R10	2.7MΩ	G3	L10	10.6	A1		
C11	575pF	C2		R11	1MΩ	G3	L11	2.8	—		
C12	60pF	C1		R12	2.2MΩ	G3					
C13	195pF	C2		R13	560Ω	G3					
C14	0.05μF	F3		R14	3.9kΩ	F4	T1	{ a 460.0 } { b 0.4 }	A1		
C15	0.01μF	D3		R15	3.9Ω	B4	T2	{ a 195.0 } { b 0.5 } { c 0.5 } { d 320.0 }	D4		
C16	0.01μF	E3		R16†	5.4Ω	F4	MR1	RMO†	F4		
C17	100pF	A1					MR2	FSW1392A†	F4		
C18	100pF	A1					S1-S12	—	D3		
C19	100pF	F3									
C20	0.01μF	F3									
C21	0.01μF	G3									
C22	0.01μF	G3									
C23	0.01μF	G3									
C24	100pF	G4									

\*Approximate D.C. resistance in ohms. †SenTerCel. ‡3.9Ω resistor+1.5Ω resistance wire (see "General Notes").

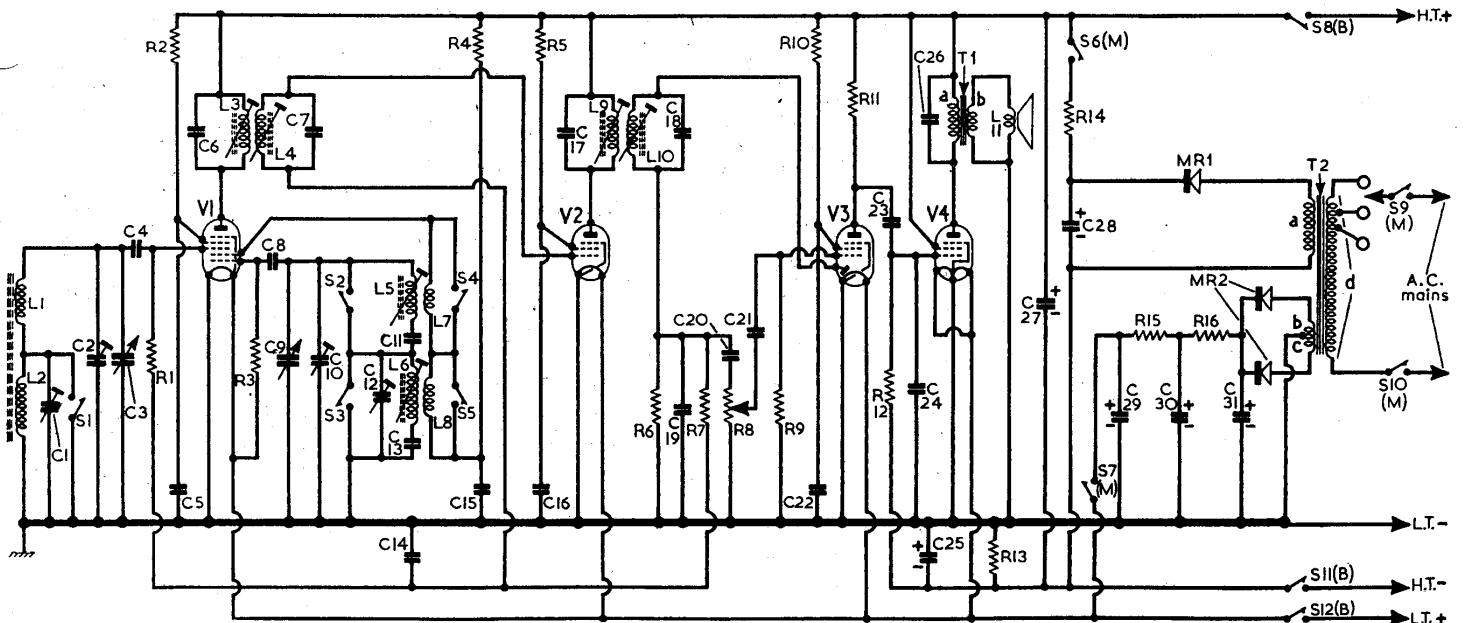

Circuit diagram of the Roberts R66. L1, L2 form the ferrite rod internal aerial. MR2 is the full-wave L.T. rectifier.

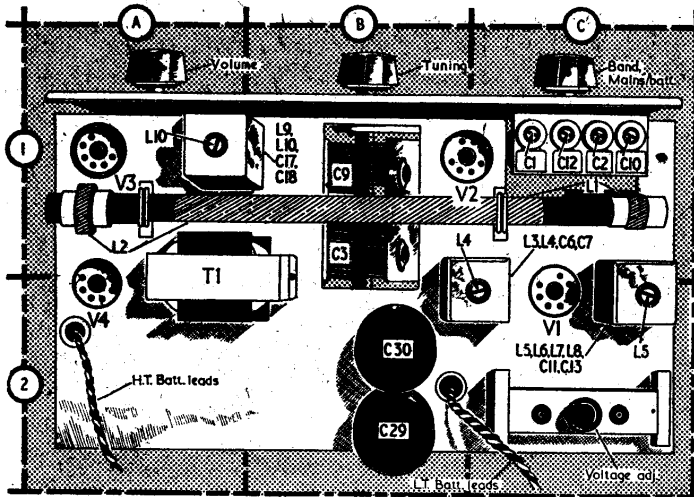

Plan illustration of the chassis. The position of the left-hand end section of L2 in location A1 is adjusted during alignment.

- 8.—Switch receiver to M.W., tune to 550m, feed in a 545.4 kc/s signal and adjust the core of L5 (C2) for maximum output. The internal aerial coil L1 (C1) should be adjusted for maximum output at this frequency by sliding it along the ferrite rod.
- 9.—Tune receiver to 200m, feed in a 1,500 kc/s signal and adjust C10 (C1) and C2 (C1) for maximum output. Repeat these adjustments, and those in operation 8, until no further improvement results.
- 10.—Switch receiver to L.W. and repeat adjustments in operations 6 and 7.

**DISMANTLING**

**Removing Chassis.**—Open back cover of carrying case and remove batteries. Place carrying case face downwards on the bench. Remove two wood screws securing chassis-supporting wood blocks to cabinet, and withdraw chassis to bottom of carrying case and withdraw it to extent of speaker leads. Unsolder speaker leads.

**VALVE ANALYSIS**

Valve voltages and currents given in the table below are those derived from the manufacturers' information, and were taken with the receiver operating from a new set of batteries. The receiver was tuned to a point at the low wavelength end of M.W. where there was no signal pick-up. Voltages were measured with an Avo Electronic TestMeter, and as this instrument has a high internal resistance, allowance should be made for the current drawn by other types of meter. The total H.T. current was 10.4mA, and the voltage measured across R13 was 5.5V (positive connection to chassis).

Valve	Anode	Screen	
		V	mA
V1 DK96 ...	Oscillator	86	0.39
		26	1.61
V2 DF96 ...		86	1.5
V3 DAF96 ...		30	0.063
V4 DL96 ...		84	5.2
MR1 RMO ...		116*	—
MR2 FSW1392A		6.7†	—

\*A.C. reading when operating from 230V mains, using 220-230V tap; "cathode" voltage 130V.  
†A.C. reading, anode to anode, when operating from 230V mains; "cathode" voltage 2.6V.

**General Notes—continued**

**Internal Aerial.**—The internal aerial assembly consists of the M.W. and L.W. tuning coils mounted at either end of a length of ferrite rod. The rod is mounted in two rubber grommets and is secured to the chassis by two metal brackets. The manufacturers state that on no account should the ferrite rod be handled when removing the chassis from its carrying case, or when picking up the chassis.

**Modification.**—In our sample model R16 consisted of a 3.9Ω resistor connected in series with a length of resistance wire measuring 1.5Ω. In some receivers this length of resistance wire may be omitted.

**CIRCUIT ALIGNMENT**

- 1.—Remove chassis from its carrying case. Switch receiver to M.W. and turn gang to minimum capacitance.
- 2.—Connect output of signal generator to junction of C3, C4 and to chassis. Feed in a 470 kc/s signal and adjust the cores of L10 (location reference A1), L9 (F3), L4 (C2) and L3 (E3) for maximum output.
- 3.—Repeat the adjustments in operation 2 until no further improvement results.
- 4.—Check that with the gang at maximum capacitance the cursor coincides with the high wavelength ends of the M.W. and L.W. scales.
- 5.—Disconnect the signal generator leads and lay them close to the ferrite rod internal aerial. Switch receiver to L.W. and tune it to "Paris" on the L.W. tuning scale.
- 6.—Feed in a 164 kc/s (1,829m) signal and adjust the core of L6 (D3) for maximum output. The internal aerial coil L2 (A1) should be adjusted for maximum output at this frequency by sliding the end section of the coil (location A1) along its ferrite rod.
- 7.—Tune receiver to "Kalundborg" on L.W. tuning scale, feed in a 245 kc/s (1,224m) signal and adjust C12 (C1) and C1 (location C1) for maximum output.

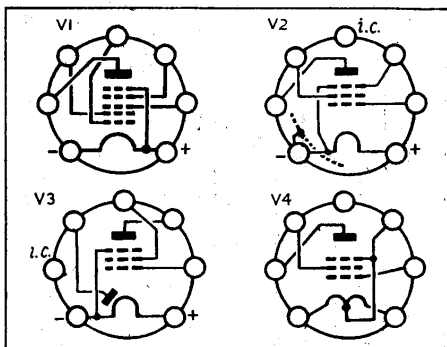

Diagrams of the valve base connections as viewed from the underside of the valve holders.

Diagrams of the band switch units as viewed from the rear of an inverted chassis as indicated in the underside illustration below.

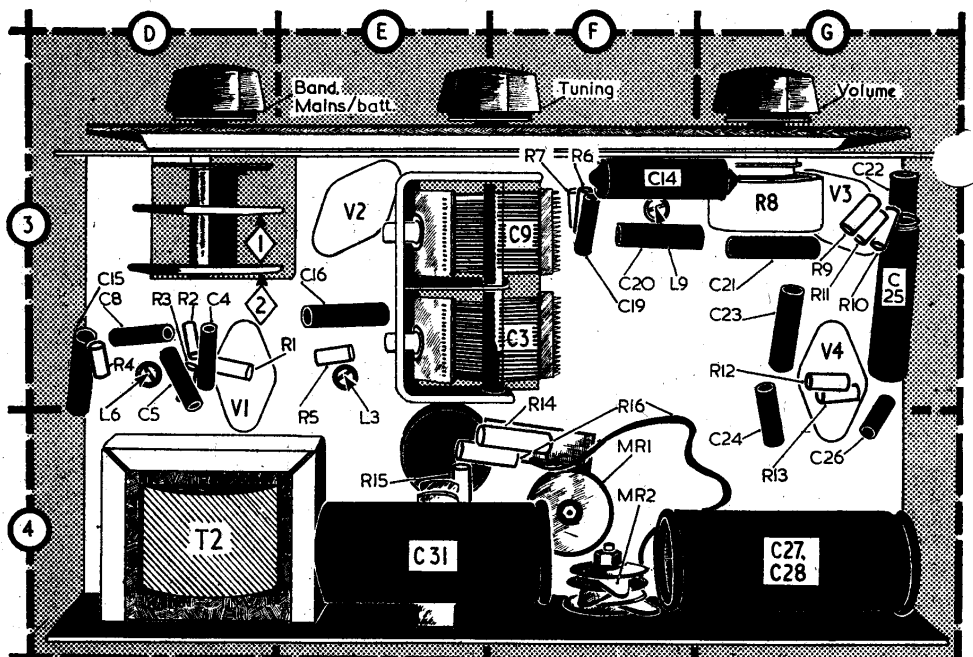
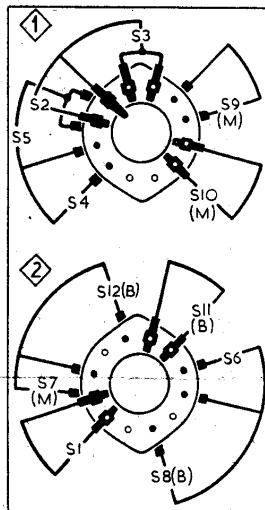

Underside illustration of the chassis. R16 in location reference F4 consists of a 3.9Ω resistor and a length of resistance wire.