

"TRADER" SERVICE SHEET
1179

ROBERTS R55

2-band All-dry Portable Superhet.

EMPLYING a ferrite rod internal aerial, the Roberts R55 is a 2-band 4-valve portable superhet designed to operate from all-dry batteries. The wavebands covered are 182-580m and 900-2,000m.

Release date and original price: October 1954, £11 18s 6d, including batteries. Purchase tax extra.

CIRCUIT DESCRIPTION

Ferrite rod internal aerial coils **L1** (M.W.) and **L2** (L.W.) are tuned by **C24** and precede heptode valve (**V1, Mullard DK96**) which operates as frequency changer with electron coupling.

Oscillator grid coils **L3** (M.W.) and **L4** (L.W.) are tuned by **C25**. Parallel trimming by **C26** (M.W.) and **C27** (L.W.); series tracking by **C8** (M.W.) and **C7**

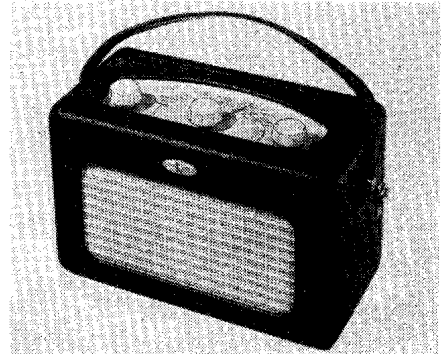

Appearance of the Roberts R55.

COMPONENTS AND VALUES

CAPACITORS		Values	Locations
C1	V1 C.G. ...	100pF	D2
C2	V1 S.G. decoupling	0.1μF	D2
C3	1st I.F. trans	100pF	C1
C4	tuning ...	100pF	C1
C5	V1 osc. C.G.	100pF	D2
C6	A.G.C. decoupling	0.1μF	E2
C7	L.W. osc. tracker	195pF	C1
C8	M.W. osc. tracker	575pF	C1
C9	Osc. anode decoupling	0.1μF	D3
C10	V2 S.G. decoupling	0.1μF	D2
C11	2nd I.F. trans.	100pF	B1
C12	tuning ...	100pF	B1
C13	I.F. by-pass ...	100pF	B2
C14	A.F. coupling	0.002μF	F2
C15	V3 S.G. decoupling	0.1μF	F3
C16	H.T. R.F. by-pass	0.1μF	F3
C17	A.F. coupling	0.002μF	F3
C18	I.F. by-pass ...	100pF	F3
C19*	V4 G.B. by-pass	20μF	F3
C20*	Battery reservoir...	8μF	F3
C21	Tone corrector ...	0.001μF	A1
C22†	L.W. aerial trim.	60pF	C1
C23†	M.W. aerial trim.	30pF	C1
C24†	Aerial tuning ...	523pF	B2
C25†	Oscillator tuning	523pF	B3
C26†	M.W. osc. trim. ...	30pF	C1
C27‡	L.W. osc. trim. ...	60pF	C1

* Electrolytic. † Variable. ‡ Pre-set.

RESISTORS		Values	Locations
R1	V1 C.G. ...	1MΩ	D2
R2	V1 S.G. feed ...	120kΩ	D3
R3	V1 osc. C.G. ...	27kΩ	D3
R4	Osc. anode feed ...	33kΩ	D3
R5	V2 S.G. feed ...	30kΩ	D3
R6	A.G.C. decoupling	2.2MΩ	E2
R7	Volume control ...	500kΩ	F2
R8	V3 C.G. ...	10MΩ	F2
R9	V3 S.G. feed ...	2.7MΩ	F2
R10	V3 anode load ...	1MΩ	F2
R11	V4 C.G. ...	2.2MΩ	F3
R12	V4 G.B. ...	510Ω	F3

OTHER COMPONENTS		Approx. Values (ohms)	Locations
L1	Internal aerial coils	0.25	C1
L2		5.5	A1
L3	Oscillator tuning coils	2.7	C1
L4		9.0	C1
L5	Oscillator reaction coils	1.5	C1
L6		5.0	C1
L7	1st I.F. trans. { Pri.	10.5	C1
L8		Sec.	10.5
L9	2nd I.F. trans. { Pri.	10.5	B1
L10		Sec.	10.5
L11	Speech coil	2.8	—
T1	O.P. trans. { Pri.	490.0	A2
	{ Sec.	0.5	—
S1-S8	Waveband/batt. sw.	—	D2

(L.W.). Reaction coupling from anode circuit by **L5** (M.W.) and **L6** (L.W.).

Second valve (**V2, Mullard DF96**) is a variable-mu R.F. pentode operating as intermediate frequency amplifier with tuned transformer couplings **C3, L7, L8, C4** and **C11, L9, L10, C12**.

Intermediate frequency 470 kc/s. Diode signal detector is part of diode pentode valve (**V3, Mullard DAF96**). Audio frequency component in its rectified output is developed across volume control **R7**, which acts as diode load, and is passed via **C14** to control grid of pentode section. I.F. filtering by **C13**.

D.C. potential developed across **R7** is fed back as bias to **V1** and **V2** giving automatic gain control.

Resistance-capacitance coupling via **R10, C17** and **R11** between **V3** and pentode output valve (**V4, Mullard DL96**).

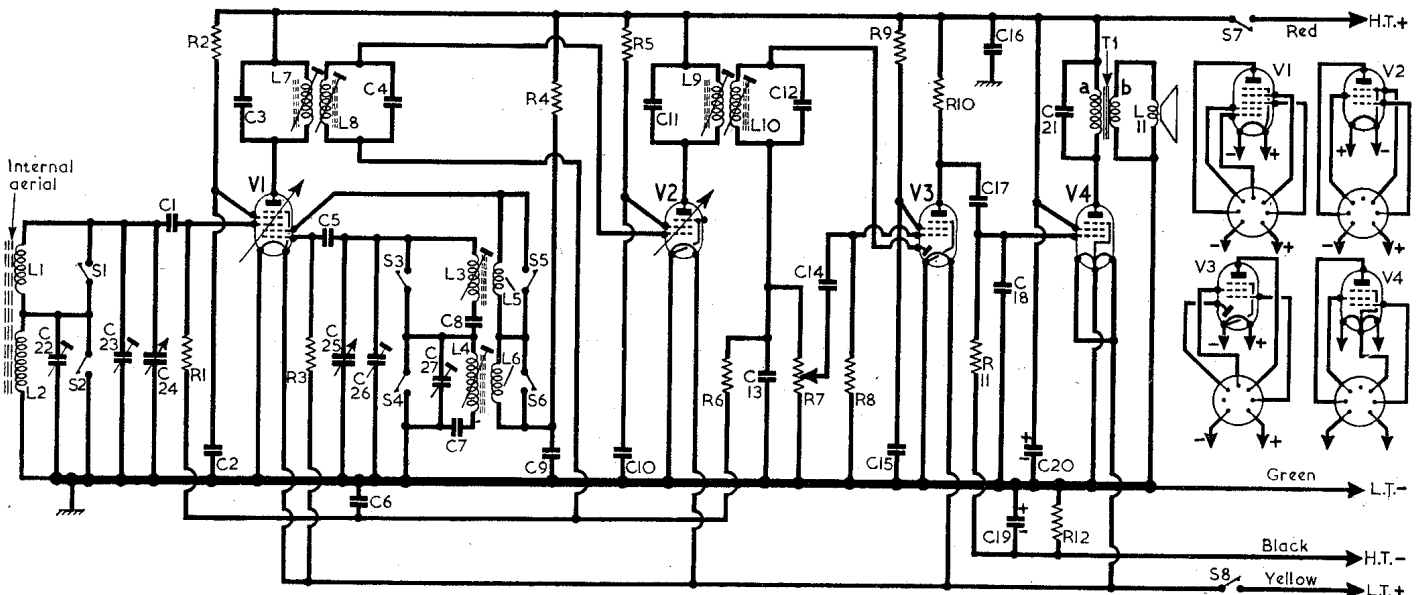

Circuit diagram of the Roberts R55. L1 and L2 are the internal aerial coils and are mounted at opposite ends of a length of ferrite rod. The pins on the battery lead connectors are identified in the rear illustration of the chassis (location reference A1).

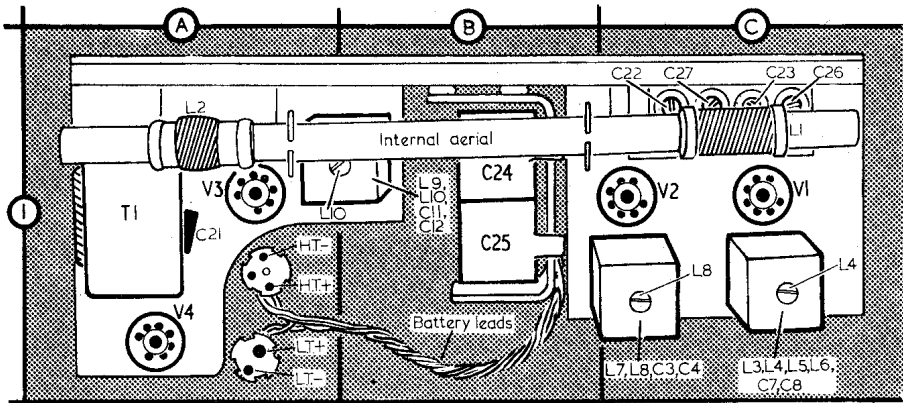

Rear view of chassis. For circuit alignment the inductance of the frame aerial coils **L1** (location reference C1) and **L2** (A1) may be varied by sliding the coils along the ferrite rod.

DISMANTLING

Removing Chassis.—Place carrying case face downwards on bench, open back cover, and remove batteries;

remove the two 4BA nuts and washers situated on the extreme left and right sides of the baffle and slide the baffle downwards to the bottom of the carrying case;

stand the carrying case in its normal position and press lightly downwards on the tuning scale window. The chassis complete with speaker should swing outwards, pivoting about the bottom edge of the baffle, and can then be withdrawn as one unit.

The chassis can be separated from the speaker assembly by removing the four wood screws which secure the edges of the chassis to it.

GENERAL NOTES

Switches.—S1—S8 are the waveband and battery switches, ganged together in a single rotary unit beneath the chassis. This unit is indicated in the front illustration of the chassis and shown in detail in the diagram below, where it is drawn as seen from beneath the chassis. The associated switch table gives the switch operations for the three control settings. A dash indicates open, and **C**, closed.

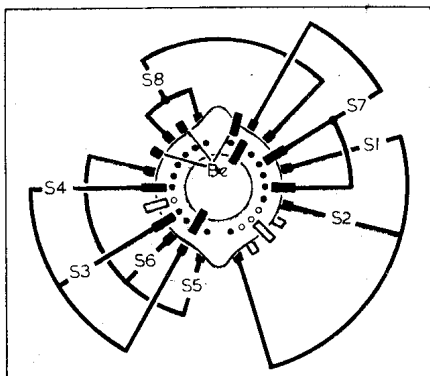

Diagram of the waveband/battery switch unit as seen from the lower edge of the chassis. The associated switch table is in column 3.

Batteries.—Those recommended by the manufacturers are as follows: H.T., Ever Ready Batrymax B126, rated at 90V; L.T., Ever Ready Alldry 4, rated at 1.5V.

Internal Aerial.—The internal aerial assembly consists of the M.W. and L.W. tuning coils mounted at either end of a length of ferrite rod. The rod is mounted in two rubber grommets and is secured to the chassis by two metal brackets.

The manufacturers state that on no account should the ferrite rod internal aerial be handled when working on the chassis.

CIRCUIT ALIGNMENT

The chassis should be removed from its carrying case to make the following adjustments accessible.

I.F. Stages.—Switch receiver to M.W. and turn gang to minimum capacitance. Connect output of signal generator to junction of **C24**, **C1** and to chassis. Feed in a 470 kc/s (638.3m) signal and adjust the cores of **L10** (location reference B1), **L9** (E2), **L8** (C1) and **L7** (D3) for maximum output. Repeat these adjustments until no further improvement results.

R.F. and Oscillator Stages.—Check that with the gang at maximum capacitance, the cursor coincides with the high wavelength ends of the M.W. and L.W. scales. Lay the signal generator output leads close to the ferrite rod internal aerial.

M.W.—Switch receiver to M.W., tune to 550m,

feed in a 550m (545.4 kc/s) signal and adjust the core of **L3** (D3) for maximum output. The internal aerial coil **L1** (C1) should be adjusted for maximum output at this frequency by sliding it along the ferrite rod. Tune receiver to 200m, feed in a 200m (1,500 kc/s) signal and adjust **C26** (C1) and **C23** (C1) for maximum output. Repeat these adjustments until no further improvement results.

L.W.—Switch receiver to L.W., tune to "Paris" on the L.W. tuning scale, feed in a 1,820m (164 kc/s) signal and adjust the core of **L4** (C1) for maximum output. The internal aerial coil **L2** (A1) should be adjusted for maximum output at this frequency by sliding it along the ferrite rod. Tune receiver to "Kalundborg" on L.W. tuning scale, feed in a 1,224m (245 kc/s) signal and adjust **C27** (C1) and **C22** (C1) for maximum output. Repeat these adjustments until no further improvement results.

Switch Table

Switches	Off	M.W.	L.W.
S1	---	---	C
S2	---	C	---
S3	---	---	C
S4	---	C	---
S5	---	---	C
S6	---	C	---
S7	---	C	C
S8	---	C	C

VALVE ANALYSIS

Valve voltages and currents given in the table below are those measured in our receiver when it was operating from a new set of batteries. The receiver was tuned to a point at the high wavelength end of M.W. where there was no signal pick-up.

Voltages were measured with an Avo Electronic TestMeter, and as this instrument has a high internal resistance, allowance should be made for the current drawn by other types of meter. Chassis was the negative connection in every case. The total H.T. current was 10mA, and the voltage measured across **R12** was 5V (positive connection to chassis).

Valve	Anode	Screen	
		V	mA
V1 DK96 ...	{ 85	73	0.2
	{ Oscillator		
V2 DF96 ...	{ 31	69	0.45
	{ 85		
V3 DAF96 ...	{ 16	31	0.02
	{ 0.06		
V4 DL96 ...	{ 81	85	1.1
	{ 5.5		

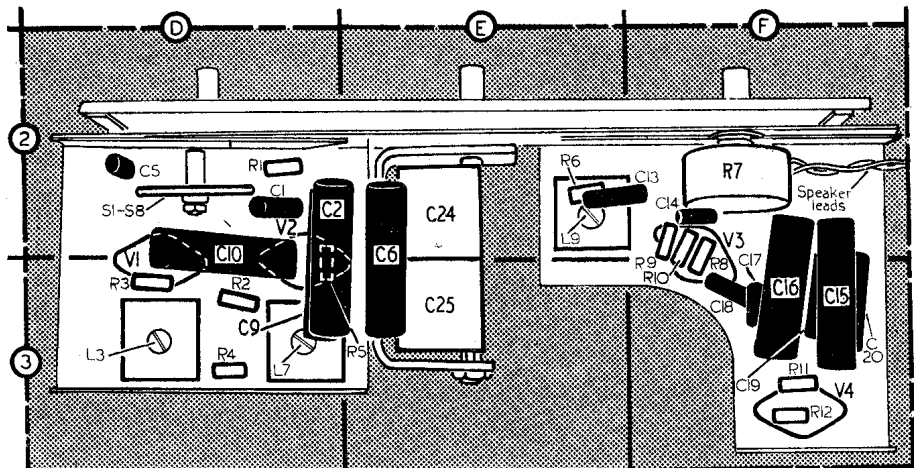

Front view of chassis. The chassis is held to the speaker baffle by means of four wood screws, and the baffle is secured to the carrying case by two 4BA nuts.