

STEREOPHONIC DUAL 14 WATT POWER AMPLIFIER

MODEL

**HF-86**



**EICO**

INSTRUCTION

MANUAL

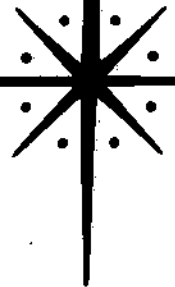

ELECTRONIC INSTRUMENT CO. INC.  
3300 NORTHERN BLVD., L. I. CITY 1, N. Y.

**EICO**

# MODEL HF 86 STEREO DUAL POWER AMPLIFIER

## general description

---

### GENERAL

The HF86 is a dual power amplifier for stereo use with the superb HF85 stereo preamp or any good stereo preamp that is self-powered. Each power amplifier is conservatively rated at 14 watts output and employs a Williamson-type circuit with a push-pull EL84 output stage. The two amplifiers may be operated in parallel to deliver 28 watts for non-stereo use; either input can be made common for both amplifiers by a service selector switch. Other convenience features include a level control at each input, an a-c power switch, two convenience outlets, and a fuse in an extractor post mounting.

The design and construction of the HF86 clearly shows the value of EICO's experience and continuous development work. Probably the most interesting innovation is a new tube type, the 12DW7, developed at EICO's request and appearing for the first time in this amplifier. This new tube is a medium- $\mu$  triode of the 12AX7 type and a low- $\mu$  triode of the 12AU7 type in a single envelope with coiled heater construction; this type is controlled in production for audio use. The 12DW7 conveniently provides significantly better performance characteristics

in the familiar voltage amplifier and split-load phase inverter of the Williamson-type circuit. The 12DW7 will also be available directly from EICO. Other important design features, characteristic of all EICO amplifiers, are a rugged and generous chassis, maximum separation of power tubes from each other and heat-sensitive components, trouble-free point-to-point wiring, and painstaking attention to reducing distortion without compromising stability. Filter electrolytics and rectifiers operate well below maximum ratings to insure long life.

The HF-86 has been designed to maintain its excellent characteristics under speaker load (including electrostatic types) as well as the resistive load normally used for testing. Phase corrections have been provided at both extremes of the audio spectrum to insure stability under all conceivable conditions and to insure that variations in components and construction will not affect the performance. Stability is maintained on all speaker taps with loads ranging from zero to infinity. Overload characteristics are excellent and the HF-86 will not exhibit bounce or flutter under pulsed conditions.

### SPECIFICATIONS

Output Power: 28 watts (two 14 watt amplifiers) continuous, 56 watts peak

IM Distortion (60 & 7000 cps at 4:1): 1.5% at 28 watts (14w. each), 0.5% at 10 watts (5w. each), 0.3% at 4 watts (2w. each)

Harmonic Distortion: 16 watts (8w. each) less than 1% from 30c to 15kc; 20 watts (10w. each) less than 1% from 40c to 15kc; 28 watts (14w. each) less than 2% from 40c to 15kc and 1% from 50c to 7kc; 20c distortion; 3% at 12.5 watts (6.25w. each)

Frequency Response: 2 watts (1w. each)  $\pm 0.5$ db 10c to 100kc

Transient Response: Excellent square wave reproduction (4 usec rise time); negligible ringing, rapid setting on 10kc square wave

Inverse Feedback: 20db

Stability Margin: 15db

Sensitivity: 1.15V for 14w output

Hum: 90db below rated output

Speaker Connections: 4, 8, 16, and 32 ohms

Controls: Level Ch. 1, Level Ch. 2, "Service Selector" switch, ON-OFF switch

Tubes: 2-12DW7, 4-EL84, 2-EZ81

Power Source: 117V, 60c

Power Consumption: 115 watts

Size: HWD - 5" x 13 1/2" x 9"

Shipping Weight: 16 lbs.

## mechanical installation

---

### GENERAL

a) **HEAT DISSIPATION (VENTILATION):** In common with other electronic equipment, the Model HF-86 produces a great deal of heat in normal operation. Unless continuous and adequate air flow is obtained around the heat producing elements, these elements will overheat and their useful life will be greatly curtailed. Adequate ventilation will be provided if the amplifier is installed in an open-back console provided that the top of the amplifier is spaced at least two inches below any shelf mounted above it. If the cabinet is enclosed at the rear, provide several large holes or slots as low down and as high up in the cabinet back as possible. As an alternate, holes may be provided in the sides, bottom, or top of the cabinet. The important thing to remember is that effective ventilation requires provision for cool air to enter at the bottom and to leave at the top.

If the amplifier is not installed in a console, it should be situated preferably on an open surface. An attractively finished matching cover for the Model HF-86 is available which will provide a "finished" appearance as well as protection when the amplifier is not installed in a console. Four rubber feet are also provided so that the amplifier will not mar the surface of furniture on which it is placed.

b) **ACCESSIBILITY TO PARTS:** Tubes are the most frequently replaced items in electronic equipment. If the amplifier is placed in a console, sufficient space should be allotted to reach and remove any tube in the amplifier. Furthermore, input and output terminals of the amplifier should be accessible to permit easy interchanging of system components for comparison. If antennas are strung around the back of the console in which the amplifier is installed, arrange them so they will not interfere.

c) **ELECTRICAL ISOLATION:** To realize the full benefit of having a power amplifier physically separate from the preamplifier-control unit and/or tuner, the power amplifier should be placed at least one foot away (more if possible) from either or both of these units.

d) **ACOUSTICAL ISOLATION:** If amplifier and speaker are installed in the same cabinet, provide sufficient separation to minimize mechanical speaker vibration reaching the amplifier. The minimum separation is about one foot.

### CONSOLE MOUNTING

Having determined a proper location for the amplifier in the particular console, the correct procedure for mounting the amplifier chassis is as follows: a) If the rubber feet have been inserted in the bottom plate, remove them (pry out with a thin screwdriver). b) Remove the 10 screws which fasten the bottom plate to the chassis. c) Place the bottom plate (bumps facing up) at the location on the shelf or the other mounting surface in which it is desired to mount the amplifier. With a sharp pencil, placed with its point directly against the edge of the lower surface of the bottom plate, draw the outline of the bottom plate on the shelf and also mark the position of the two extreme holes on both the long sides (front & rear). d) Remove the bottom plate and drill each of the marked holes on the shelf to a diameter of 1/4". e) Re-fasten the bottom plate to the chassis, with the 6 #8 X 3/8 screws previously removed, using the center holes on each of the long sides and the two holes on each of the short sides. f) Replace the chassis on the shelf, positioning it exactly in the outline previously drawn. g) From the bottom side of the shelf, insert a #8 X 1" screw with a 1/2" flat washer against the head through each of the four front and rear holes. These screws engage the stamped nut over each hole on the chassis flange and when tightened secure the chassis to the shelf.

## electrical installation

---

### POWER

a) **POWER REQUIREMENTS:** The EICO Model HF-86 requires 115 watts at 110 to 120 volts, 60 cycles AC.

b) **REMOTE SWITCHING:** The EICO Model HF-86 is provided with its own ON-OFF power switch. If the HF-86 power amplifier is being used with a preamplifier, such as the EICO HF-85, or a self-powered tuner-pre-amplifier, the line cord of the HF-86 is inserted in a switched 117VAC convenience outlet in the control unit. Turn the power switch on the HF-86 to ON. Note: When using a self-powered preamplifier-control unit, touch one end of a wire to the preamplifier chassis and the other end to the power amplifier chassis. If a spark oc-

curs, pull out the HF-86 line cord plug and re-insert it with the prongs reversed.

c) **CONVENIENCE OUTLETS:** When the HF-86 is used with a preamplifier, such as the EICO HF-85, normally the convenience outlets on the preamplifier will be used. However, the HF-86 outlets may be used also, if desired, in which case both of them will be "switched".

### INTERCONNECTION OF COMPONENTS: SIGNAL

All input connections are to be made using single conductor shielded cable. Unless the source has a low impedance output, such as a cathode follower (with which up to 50 ft. of cable can be used), use the shortest possible con-

nection. In any case, use a low capacity type of shielded cable (as low as 25 mmf capacity per foot is available). Both ends of the cable must be fitted with RCA type phono plug connectors. For speaker connections, use plastic covered lamp cord or flat ribbon twin lead.

(1a, 1b, & 1c below are possible input connections)

1a) STEREO CONTROL PREAMPLIFIER TO HF86 DUAL POWER AMPLIFIER: Use two cables as described above. Connect one cable from preamplifier output 1 to input 1 on the HF-86. Connect another from preamplifier output 2 to input 2 on the HF-86. Set the Service Sel switch at the SEPARATE position. Power amplifier can deliver 14 watts per channel. DO NOT use dual conductor shielded lead.

1b) MONAURAL CONTROL PREAMP TO HF86 DUAL POWER AMPLIFIER: Use one cable as described above. Connect this cable from the preamplifier output to input 2 on the HF-86. Put the Service Sel switch into the COMBINED position. Power amplifier can deliver a total of 28 watts to the speaker.

1c) USING YOUR OLD AMPLIFIER: You can use your old power amplifier or integrated amplifier for one stereo channel, and the HF-86 connected for parallel operation of the dual amplifiers for the second stereo channel. This may be worthwhile only if your old amplifier has a rated power output of at least 20 watts. Connect one cable from stereo preamp output 1 to input 2 of the HF86 and set the Service Sel switch at the COMBINED position. With the speaker connection terminals of the dual amplifiers connected in parallel, the HF86 can deliver 28 watts to the speaker in stereo channel 1. Connect another cable from stereo preamp output 2 to input of your old power amplifier or to the tuner or auxiliary input of your old integrated amplifier. (In the latter case, set the tone controls of the old amplifier to "flat" and loudness contour or filter controls to no effect). The power capability of the second channel will then be the same as your old amplifier.

(2a, 2b, 2c, & 2d below are possible output connections)

2a) In the situation described in 1a above, for stereo operation connect one speaker system between "G" and the appropriate impedance tap on the speaker connection terminal board for amplifier 1. Similarly, connect the appropriate impedance tap on the speaker connection board for amplifier 2. If you have only one speaker system at this time, and wish to use the power of both amplifiers combined to drive it, then use the parallel operation connection described in 2d below.

2b) In the situation described in 1b above, if you have two speaker systems connect one to each speaker connection terminal board (one for each amplifier) just as described in 2a above. If you have only one speaker system, use the parallel operation connection described in 2d below.

2c) In the situation described in 1c above, it is implied that you have two speaker systems. Connect one speaker system to your old amplifier and the second speaker system to the HF-86 dual power amplifiers connected in parallel as described in 2d below.

2d) Parallel operation of the HF86 dual power amplifiers is accomplished as follows: First determine the rated impedance of the speaker system to be connected to the paralleled amplifiers and multiply it by two. The result will be 8, 16, or 32 ohms. Locate the connection terminals on each of the two speaker connection terminal boards on the HF86 assigned to the tap of this value. Connect an external jumper wire between this particular pair of terminals (32 to 32 for a 16Ω speaker, 16 to 16 for an 8Ω speaker, or 8 to 8 for a 4Ω speaker). Finally, connect the speaker between one of the "G" terminals and one of the pair of terminals connected together by the jumper wire.

## **maintenance**

---

### **CONTROL ADJUSTMENTS**

a) The INPUT LEVEL ADJ. controls are intended to protect the speaker system from "blasting" should someone turn the preamplifier-control unit level controls to full, by permitting you to attenuate the preamplifier output signal by any desired amount at the input to the power amplifier where it can not be "fiddled" with. Start by setting the INPUT LEVEL maximum counter-clockwise (maximum attenuation), using a screwdriver. Set the

LEVEL control on one channel at the midpoint of its range of its range of rotation. Turn your phonograph on and play an average orchestral record. Then slowly rotate the appropriate INPUT LEVEL ADJ. control clockwise until the music is at normal (or concert) listening level. Repeat for the second channel. This completes the adjustment.

b) ON-OFF SWITCH: Should be set at the ON position when the unit is used with a preamplifier. It may be used as a power on-off switch when the amplifier is accessible.

## TROUBLE-SHOOTING PROCEDURES

Your amplifier should require little service except for normal tube replacement. We recommend no substitutions for the tube types used in this amplifier. The EL84, and EZ81 types are distributed nationally by the Amperex Electronic Corporation (230 Duffy Ave., Hicksville, L. I., N. Y.) and Mullard Ltd. (International Electronics Corp., 81 Spring St., N. Y. 12, N. Y.) The 12DW7 type is made by several U. S. manufacturers and is available nationally. If necessary, replacements at any time can be obtained directly from EICO.

To facilitate servicing, remedial and trouble-shooting procedures have been provided in the TROUBLE-SHOOTING CHART that follows. A VOLTAGE AND RESISTANCE CHART is also provided as an aid in locating defective components and to permit a careful, stage-by-stage check of the amplifier. DC operating voltages are given both at no signal and at a signal developing 14 watts output as well as the corresponding 1 kc signal voltages.

To isolate the source of unusual hum or noise in your system, first turn off the AC power and then unplug the audio cable connecting to the amplifier input. Then turn the AC power on again and note whether hum or noise has decreased. If it has, the fault is in the preamplifier or associated equipment and measures should be taken to correct it as described in the service notes for these units. If it is desired to provide a good building ground for your entire system, run a lead from under either speaker connection terminal "G" to a cold water pipe. Do not connect such a ground wire to other components in the system.

If the trouble is no output or low output and the amplifier is suspected, check AC signal voltages starting at the input and work step-by-step toward the output, using a sine-wave audio signal generator and a VTVM. Set the input signal to 1 volt. The corresponding grid and plate signal voltages for this input are indicated on the voltage chart. Repeat for the second channel. This procedure should suffice to localize the defective stage.

If the trouble is an excessively distorted output, try tube replacement, signal tracing, or proceed directly to voltage and resistance measurements.

When the defective stage is localized, proceed to a resistance and voltage check of the stage, using the data

In the Voltage and Resistance chart. Disconnect the amplifier from the power line and discharge capacitors, prior to making any resistance check or removing the EL84 output tubes. Do not turn the amplifier on with any of the output tubes removed.

## CHECKING A TYPICAL TUBE STAGE

1. Check tube.
2. Check plate and cathode resistors.
3. Check coupling capacitors for leakage or short.
4. For output stage, check dc resistance of transformer windings.
5. Check for open grid leak resistor.
6. Check cathode by-pass capacitors for short.
7. If no or low B+ voltage on the tube, check decoupling path for open or defective R27 or R28, and filter capacitor, C15, for short.
8. If wiring and circuit components including the tube check O. K. and B+ voltage is excessive, check the decoupling path for short or defective R27 or R28.

## SERVICE

If trouble develops in your instrument which you can not remedy yourself, write to our service department listing all possible indications that might be helpful. If desired you may return the instrument to our factory where it will be placed in operating condition for \$7.50 plus the cost of parts replaced due to their being damaged in the course of construction. NOTE: Before returning this unit, be sure all parts are securely mounted. Attach a tag to the instrument, giving your home address and the trouble with the unit. Pack very carefully in a rugged container, using sufficient packing material (cotton, shredded newspaper, or excelsior), to make the unit completely immovable within the container. The original shipping carton is satisfactory, providing the original inserts are used or sufficient packing material inserted to keep the instrument immovable. Ship by prepaid Railway Express, if possible, to Electronic Instrument Co., Inc., 33-00 Northern Blvd., Long Island City 1, New York. Return shipment will be made by express collect. Note that a carrier cannot be held liable for damages in transit if packing IN HIS OPINION, is insufficient.

## GENERAL INSTRUCTIONS

The section of the manual beginning with this page is the **CONSTRUCTION** section. All pages in this section have page numbers followed by "C" (1C, 2C, etc.). The **INSTRUCTION** section resumes on the pages following the **CONSTRUCTION** section. Note that the **CONSTRUCTION** section is located centrally in the book and may be removed without disrupting the **INSTRUCTION** section that both precedes it and follows it.

Care taken in the construction of this unit will reward the constructor with many years of satisfactory service and greater confidence in his unit. Do not rush the construction. Take all the time necessary for proper assembly and wiring. Furthermore, we urge strongly that you follow the wire and parts layout shown in the pictorial diagrams as closely as possible. Very often wires are placed as shown for a good reason, and certainly the appearance of the completed unit will be improved, and the difficulty of finding a wiring error will be reduced by following the wire and parts layout shown.

**UNPACKING THE KIT:** Unpack the kit carefully and check each part against the parts list. If you have trouble identifying any parts refer to the pictorial diagrams or the color code chart. You will find that the value of a component will vary within the allowable circuit tolerance. For example, a 4.7K,  $\pm 10\%$  resistor may measure anywhere between 4.2K and 5.2K. Tolerances on paper capacitors are substantially greater, and the tolerance for electrolytics is usually  $+100\%$  and  $-50\%$ .

**CONSTRUCTION HINTS: USE THE BEST GRADE OF ROSIN CORE SOLDER ONLY**, preferably one containing the new activated fluxes such as Kester "Resin-Five", Ersin "Multiflucore" or similar types. **UNDER NO CIRCUMSTANCES USE ACID CORE SOLDER OR ACID FLUX** since acid flux can cause serious corrosion. Before soldering, make certain of a good mechanical connection. Use a clean, freshly tinned soldering iron, and place the solder on the joint itself. Do not remove the soldering iron until the solder flows and check to see that the resulting joint is smooth and shiny when the solder has cooled. There are two extremes to be avoided; too little heat and too much heat. If too little heat is supplied, the joint will appear pitted and gray, indicating a rosin joint which is unsatisfactory. On the other hand, if too much heat is applied to a joint, the parts connected to it may either change value, lose their protective coating, or break down. If you are soldering close to a part, hold the lead between the part and the joint being soldered with the tip of a pair of longnose pliers. The pliers will conduct the heat away and prevent the component from being unduly overheated. If for any reason it is necessary to resolder a joint, be sure to use new solder.

It should also be noted that the leads on resistors, capacitors, and transformers are often longer than required. These leads should be trimmed to the proper length when necessary. Do not cut any lead until you have determined the required length when the lead is routed as shown in the diagrams.

**BASIC TOOLS REQUIRED:** These basic tools are required for the construction of the amplifier.

1. Screwdriver - 3/16 in. to 1/4 in. blade
2. Screwdriver - 1/8 in. blade
3. Longnose pliers - 5 in. or 6 in.
4. Diagonal cutters
5. Soldering iron (100 watts), soldergun, or pencil iron (35 watts)
6. Gas pliers
7. High quality rosin or equivalent synthetic flux core solder. Do not use acid or paste flux under any circumstances.

A set of socket wrenches and a wire stripper are also very useful supplementary tools.

**PARTS IDENTIFICATION:** Please note that many of the resistors and capacitors for which color coding is given may not be color coded, but have their values and ratings printed. To aid in rapid identification, keep in mind that 10% and 20% resistors are almost always color coded, whereas 1% and 5% resistors and all capacitors usually have their values printed. Printed numbers may appear with the letter "K", indicating that the number is to be multiplied by 1,000. The letter "M" indicates a multiplication by 1,000,000. The abbreviation "mf" indicates microfarads or 1/1,000,000 farad; "mmf" indicates microfarads or 1/1,000,000 of a microfarad. The alternate way of writing capacitor values is indicated in the construction book when the component is used. Please note the following examples of relationship between units of value.

$$\begin{aligned} 1,000,000 \text{ micro-farads (mf)} &= 1 \text{ microfarad (mf)} \\ 10,000 \text{ mmf} &= 10\text{K mmf} = .01 \text{ mf} \\ 1,000,000 \text{ ohms } (\Omega) &= 1000 \text{ kilohms} = 1 \text{ megohm (M}\Omega) \\ 2,700,000\Omega &= 2,700\text{K}\Omega = 2.7\text{M}\Omega \\ 470,000\Omega &= 470\text{K}\Omega = 0.47\text{M}\Omega \\ 2700\Omega &= 2.7\text{K}\Omega \end{aligned}$$

**CONSTRUCTION PROCEDURE:** The following pages contain complete step-by-step mounting and wiring procedures. Please note that your model HF-86 Power Amplifier consists of two identical signal channels and that the procedures for wiring these channels are given in parallel. This means that a wiring connection made in one channel can be used as a check on the procedure of the second channel.

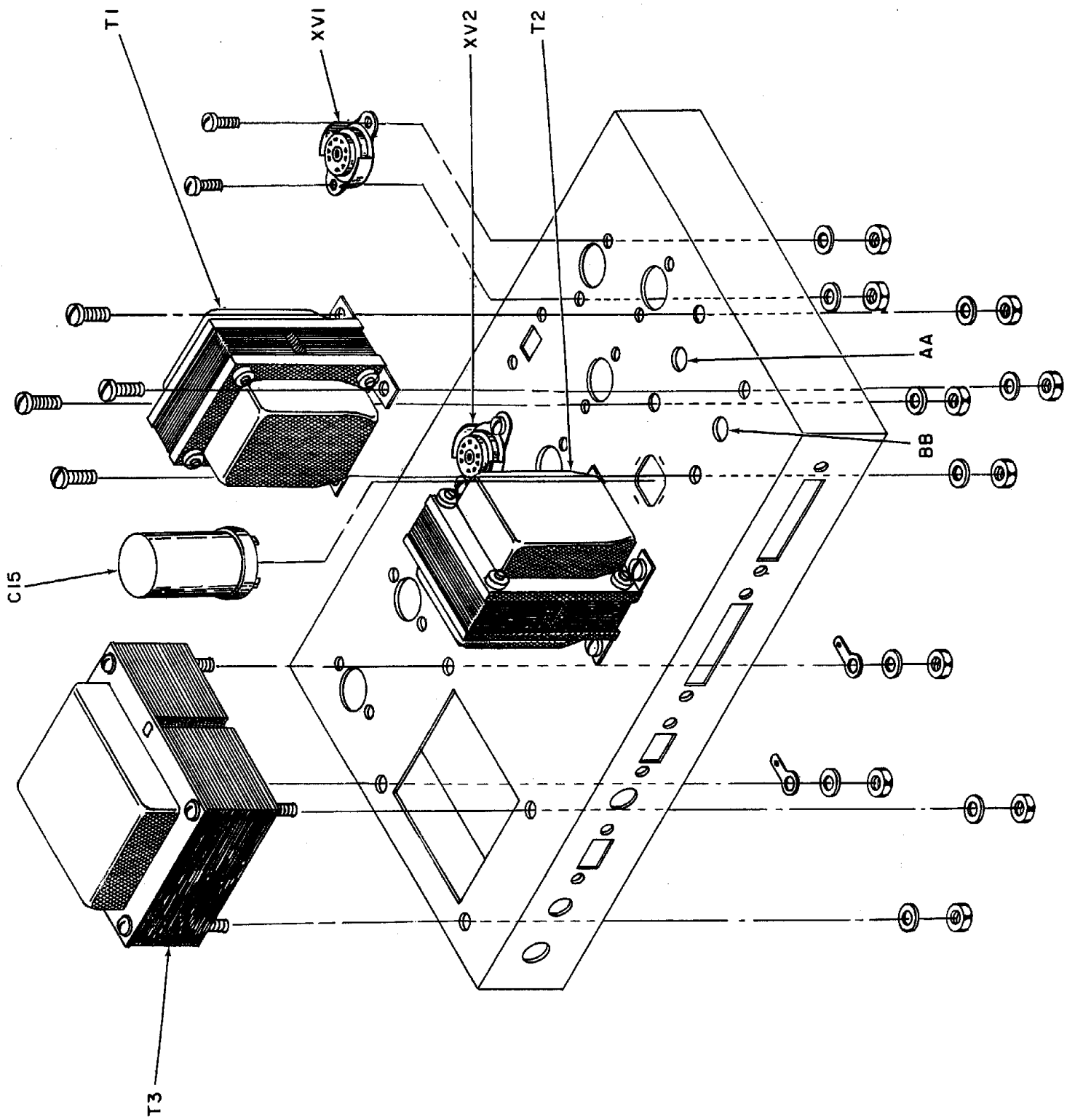

Figure 1. Assembly of Components to Top of Chassis

If you do not have a work bench at home and are planning to use your kitchen or dining room table as a work area, be sure to cover the table with a protective material. Plywood or masonite will do nicely and will eliminate the possibility of scratching or burning the table top.

The parentheses preceding each step number is provided as a check off for each completed step. Check off each completed step so that if you leave your work and return later, you will know what step is next.

Bend the ground lug tabs on tube sockets toward the chassis to prevent accidental shorting to the socket pins. When the leads on transformers are too long, cut them to the size given in the procedure. In each case, after cutting leads to the specified size, strip back 1/4 inch of the insulation so that the bare wire shows. Then tin the wire by melting solder onto the wire with a hot iron.

#### TOP OF CHASSIS ASSEMBLY

EXCEPT AS NOTED, SEE FIGURE 1 FOR ALL STEPS ON THIS PAGE

(\*) 1. On power transformer T3 (30021), cut both red and both green leads to 6 in., the red-yellow lead to 2-1/2 in., the white lead to 3 in., the two black leads to 3-1/2 in., and the two yellow leads to 4-1/2 in. Mount T3 as shown, with the red leads closest to the side of the chassis. (See figure 4.) Use two No. 8 ground lugs, four No. 8 lockwashers, and four No. 8-32 hex nuts.

(\*) 2. On output transformer T1 (32013), cut the brown, yellow, green,

orange, and black leads to 2-1/2 in. Cut the brown-yellow lead to 1-1/2 in., the blue lead to 2-1/2 in., and the red lead to 3-1/2 in.

Pull the brown-yellow, blue, and red leads through hole AA in the chassis. Pull the remaining leads through hole BB. Use four No. 8-32 screws, four No. 8 lockwashers, and four No. 8-32 hex nuts to mount the transformer.

(\*) 3. On output transformer T2 (32013), cut the brown, yellow, green, and orange leads to 3-1/2 in. Cut the blue, yellow-brown, and black leads to 3 in., and the red lead to 2 in. Pull the brown-yellow, blue, and red leads through the chassis opening closest to T3. Pull the remaining leads through the chassis opening furthest from T3. (See figure 4.) Use four No. 8-32 screws, four No. 8 lockwashers, and four No. 8-32 hex nuts to mount the transformer.

(\*) 4. Mount two 9-pin miniature tube sockets (with shield supports) XV1 and XV2, as shown. Note that the sockets should be oriented so that the large space between socket pins is directed towards transformer T3. Use two No. 4-40 screws, two No. 4 lockwashers and two No. 4-40 hex nuts to mount each socket. (See figure 4.)

(\*) 5. Mount electrolytic can capacitor C15, as shown. Note orientation of half-moon, square, and triangle near lugs as shown in figure 4. Insert the capacitor mounting tabs into the slots in the chassis and twist the tabs a little less than a quarter turn. Do not twist the tabs excessively or they will shear off. Solder the capacitor tab without a hole, to the chassis at the slot in the chassis.



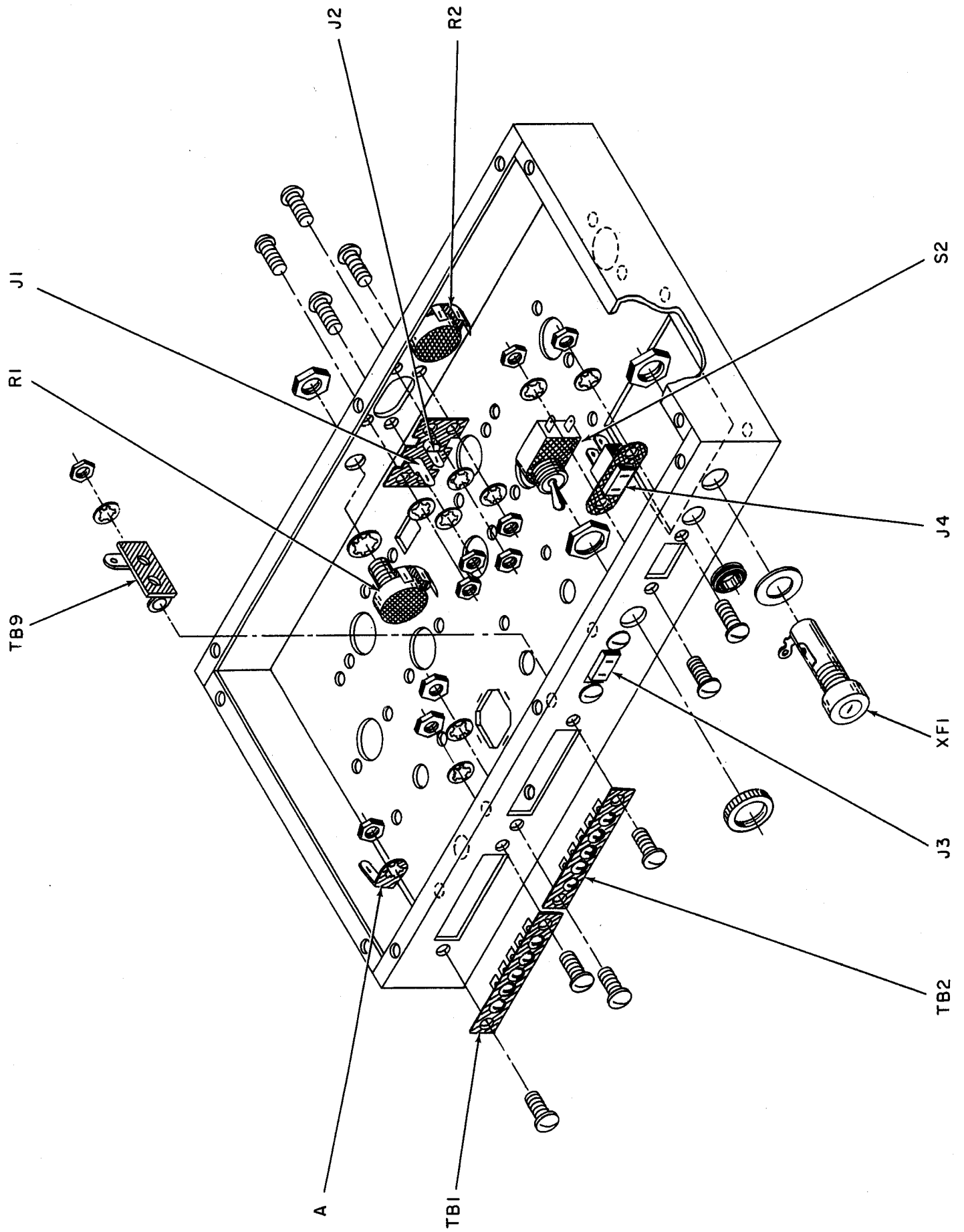

Figure 2. Assembly of Components to Front and Rear Aprons

## FRONT AND REAR APRON ASSEMBLY

SEE FIGURE 2 FOR ALL STEPS ON THIS PAGE

- (✓) 1. Mount two five screw terminal boards TB1 and TB2, from outside the chassis, as shown. Each terminal board is mounted with two No. 6-32 screws and hex nuts. However, one of the screws for TB1 also mounts a No. 6 ground lug and one of the TB2 mounting screws also mounts TB9, a one post upright right terminal strip. Place No. 6 lockwashers under all hex nuts except the one holding the No. 6 lug.
- (✓) 2. Mount convenience outlets J3 and J4, as shown. Use two No. 6-32 screws, two No. 6 lockwashers, and two No. 6-32 hex nuts for each outlet.
- (✓) 3. Mount toggle switch S2, using a 15/32-32 round ring nut outside

the chassis and a 15/32-32 hex nut inside the chassis. Adjust the hex nut so that only 1/16 in. of the screw threads can be seen outside the chassis. Now screw the ring nut on.

- (✓) 4. Mount fuseholder XF1, as shown. Use a thin rubber washer outside the chassis. Use a 15/32-32 hex nut but do not tighten too much or the holder will crack.
- (✓) 5. Push a rubber grommet into the remaining hole in the rear apron of the chassis, next to the fuseholder.
- (✓) 6. Mount potentiometers R1 and R2, as shown. Use a 3/8 in. lockwasher inside the chassis and a 3/8 in. hex nut outside the chassis apron for each potentiometer.
- (✓) 7. Mount dual input jack strip J1 and J2, as shown. Use four No. 4-40 screws, four No. 4 lockwashers, and four No. 4-40 hex nuts.

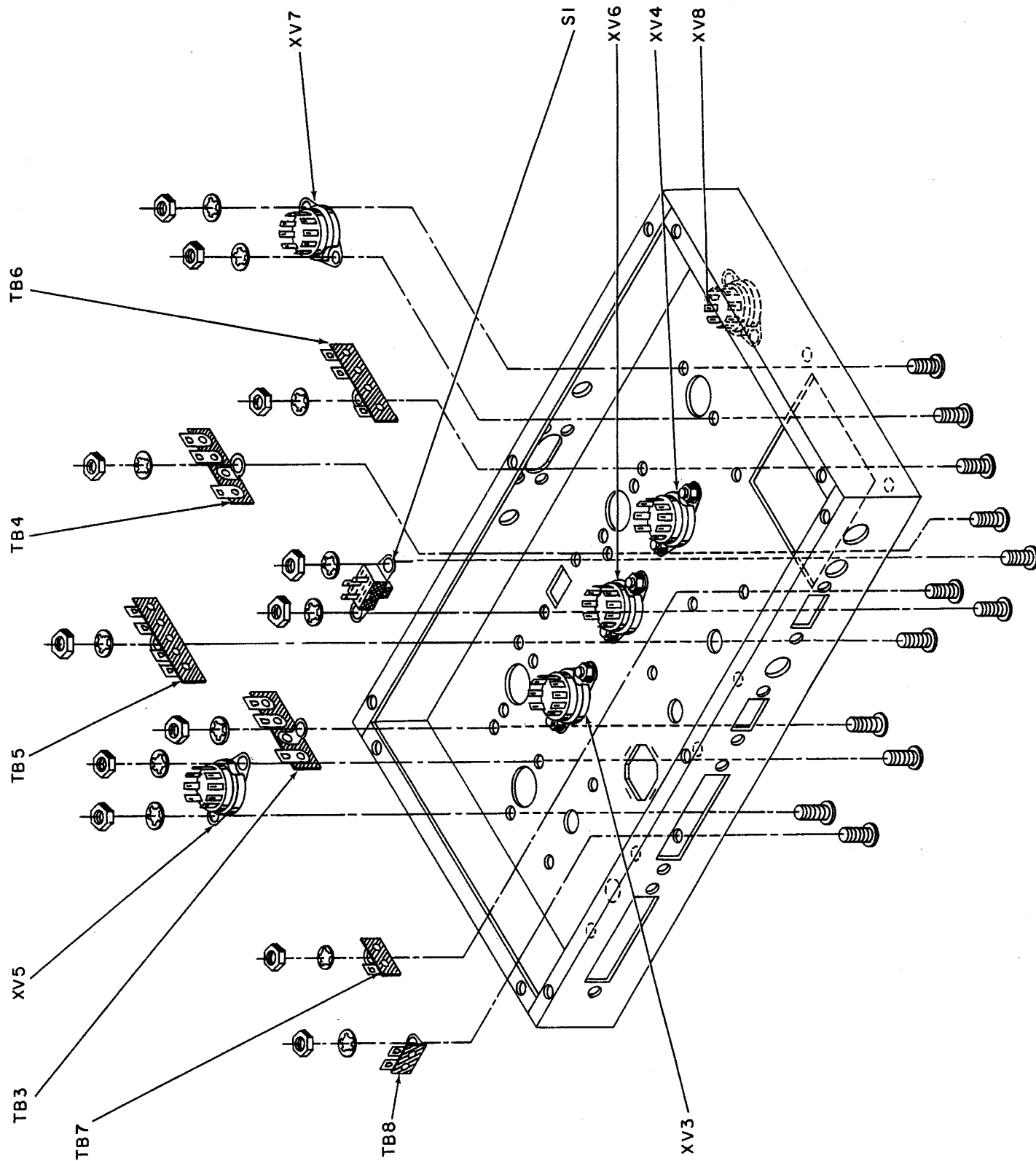

Figure 3. Assembly of Components to Bottom of Chassis

TB3  
TB4

TB5

TB6

BOTTOM OF CHASSIS ASSEMBLY

SEE FIGURE 3 FOR ALL STEPS ON THIS PAGE

- ( ) 1. Mount tube sockets XV3 through XV6, as shown. Orient each socket so that the large space between pins 1 and 9 is directed away from power transformer T3. (See figure 4.) Use two No. 4-40 screws, two No. 4 lockwashers and two No. 4-40 hex nuts to secure each socket.
- (X) 2. Mount tube sockets XV7 and XV8, as shown. Orient each socket so that the large space between pins 1 and 9 is directed away from power transformer T3, towards the front apron. (See figure 4.) Use two No. 4-40 screws, two No. 4 lockwashers and two No. 4-40 hex nuts to

secure each socket.

- (X) 3. Mount 3 post, 2 right terminal strips TB3 and TB4, 4 post terminal strip TB5, and 3 post, 2 left terminal strip TB6, as shown. Use one No. 6-32 screw, one No. 6 lockwasher, and one No. 6-32 hex nut to mount each terminal strip.
- (X) 4. Mount one post right terminal strip TB7 and one post right with ground terminal strip TB8, as shown. Use one No. 6-32 screw, one No. 6 lockwasher, and one No. 6-32 hex nut for each strip.
- (X) 5. Mount slide switch S1, as shown, using two No. 4-40 screws, two No. 4 lockwashers, and two No. 4-40 hex nuts.

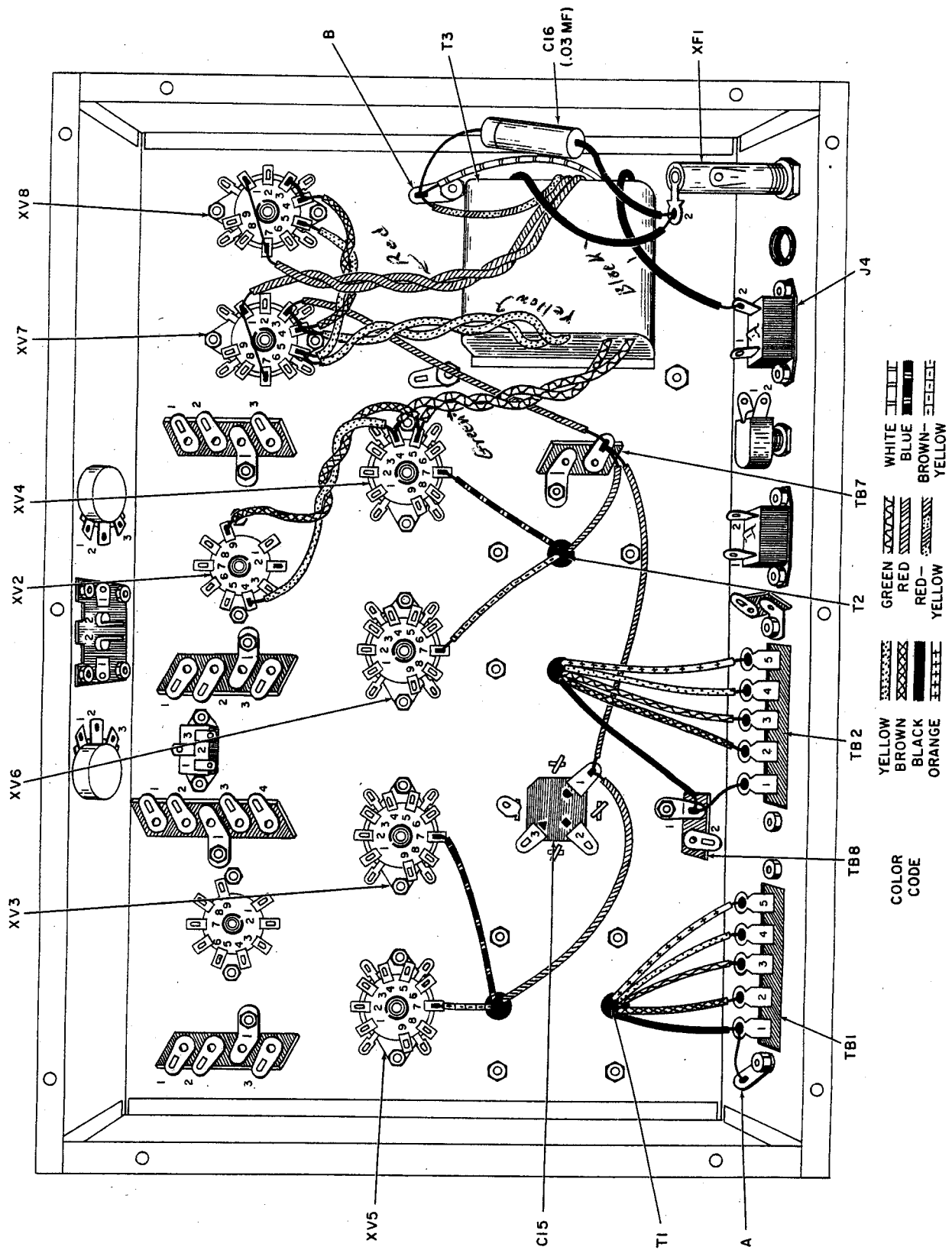

Figure 4. Preliminary Wiring

# WIRING INSTRUCTIONS

SEE FIGURE 4 FOR ALL STEPS ON THIS PAGE

The following table has been prepared to save you time during the wiring procedure. Three basic wire colors are used for interconnections in your kit. Cut the wires to the sizes indicated in the table, and strip off 1/4 in. of insulation from the ends of each wire. Keep the wires in separate color and size groups. The numbers in the table indicate quantity. For example, cut six 4 in. pieces of yellow wire and three 3 in. pieces of red wire. Use the ruler at the bottom of this page to measure wire lengths.

Size	1	2	3	4	4-1/2	5	8
Yellow wire	2	2	2	6	-	-	-
Brown wire	-	1	3	6	-	-	2
Red wire	-	-	3	3	2	2	-

Cut a shielded wire to 4 in. Remove 1/2 in. of black insulation and metal shield from one end, and 1/2 in. of black insulation only, from the other end. Now strip off 1/4 in. of white insulation from each end.

- (\*) 1. Connect a 5 in. piece of red wire from C15-1 to TB7 and a 4-1/2 in. piece of red wire from TB7 to XV7-3.
- (\*) 2. Connect a 1 in. piece of bare wire from TB1-1 to ground lug A. Solder the connection made at the ground lug.
- (\*) 3. From output transformer T1, connect the black lead to TB1-1, the brown lead to TB1-2, the green lead to TB1-3, the yellow lead to TB1-4 and the orange lead to TB1-5. Solder two connections made at TB1-1 and each connection made at TB1-2, TB1-3, and TB1-4.
- (\*) 4. On transformer T1, connect the red lead to C15-1, the blue lead to XV3-7, and the brown-yellow lead to XV5-7. Solder the connection made to XV3-7 and the connection made to XV5-7.
- (\*) 5. Connect a 1 in. piece of bare wire from TB2-1 to TB8-1. Solder the connection made at TB2-1.
- (\*) 6. From output transformer T2, connect the black lead to TB8-1, the

brown lead to TB2-2, the green lead to TB2-3, the yellow lead to TB2-4, and the orange lead to TB2-5. Solder each connection made to TB2-2, TB2-3, TB2-4, and two connections made at TB8-1 (D5B, mislabeled).

- (\*) 7. On transformer T2, connect the red lead to TB7, the blue lead to XV4-7, and the brown-yellow lead to XV6-7. Solder the connections made to XV4-7 and XV6-7, and three connections made at TB7.
- (\*) 8. On power transformer T3, twist the red leads together and connect one lead to XV7-1 and the other lead to XV8-7. Now take a 3/4 in. piece of bare wire and connect XV7-1 to XV7-7. Use another 3/4 in. piece of bare wire to connect XV8-1 to XV8-7. Solder two connections made at XV7-1, two connections made at XV8-7, the connection at XV8-1, and the connection at XV7-7.
- (\*) 9. Twist the yellow leads from T3 and connect one lead to XV7-4 and the other lead to XV7-5. Take a 4 in. piece of yellow wire and a 4 in. piece of brown wire and connect the yellow wire to XV7-5 and the brown wire to XV7-4. Now twist the wires together and connect the other end of the yellow wire to XV8-5 and the other end of the brown wire to XV8-4.
- (\*) 10. Take a 3/8 in. piece of bare wire and connect XV7-4 to XV7-3. Connect another 3/8 in. bare wire between XV8-4 and XV8-3. Now solder two connections at XV7-3, three at XV7-4, and two at XV7-5. Solder one connection at XV8-3, two at XV8-4, and one at XV8-5.
- (\*) 11. On power transformer T3, twist the green leads together and connect one lead to XV4-4 and the other lead to XV4-5. Connect the red-yellow lead and the white lead from T3 to ground lug B. Connect the black lead closest to J4, to J4-2. Connect the other black lead to XF1-2.
- (\*) 12. Cut both leads on .03 mfd capacitor C16 to 1-1/4 in. Connect one lead of the capacitor to ground lug B. Place 1 in. of spaghetti on the other lead and connect it to XF1-2. Now solder two connections made at XF1-2 and three connections made at ground lug B.
- (\*) 13. Connect a 4 in. piece of yellow wire to XV4-4 and a 4 in. piece of brown wire to XV4-5. Twist the wires together, as shown in figure 4. Connect the other end of the yellow wire to XV2-4 and the other end of the brown wire to XV2-9. Now solder two wires connected to XV4-4 and the two wires connected to XV4-5.

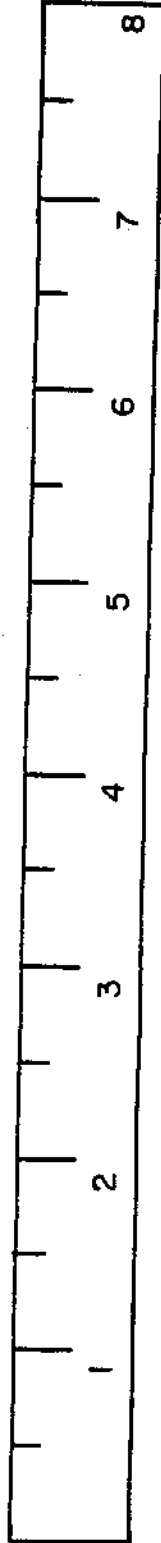

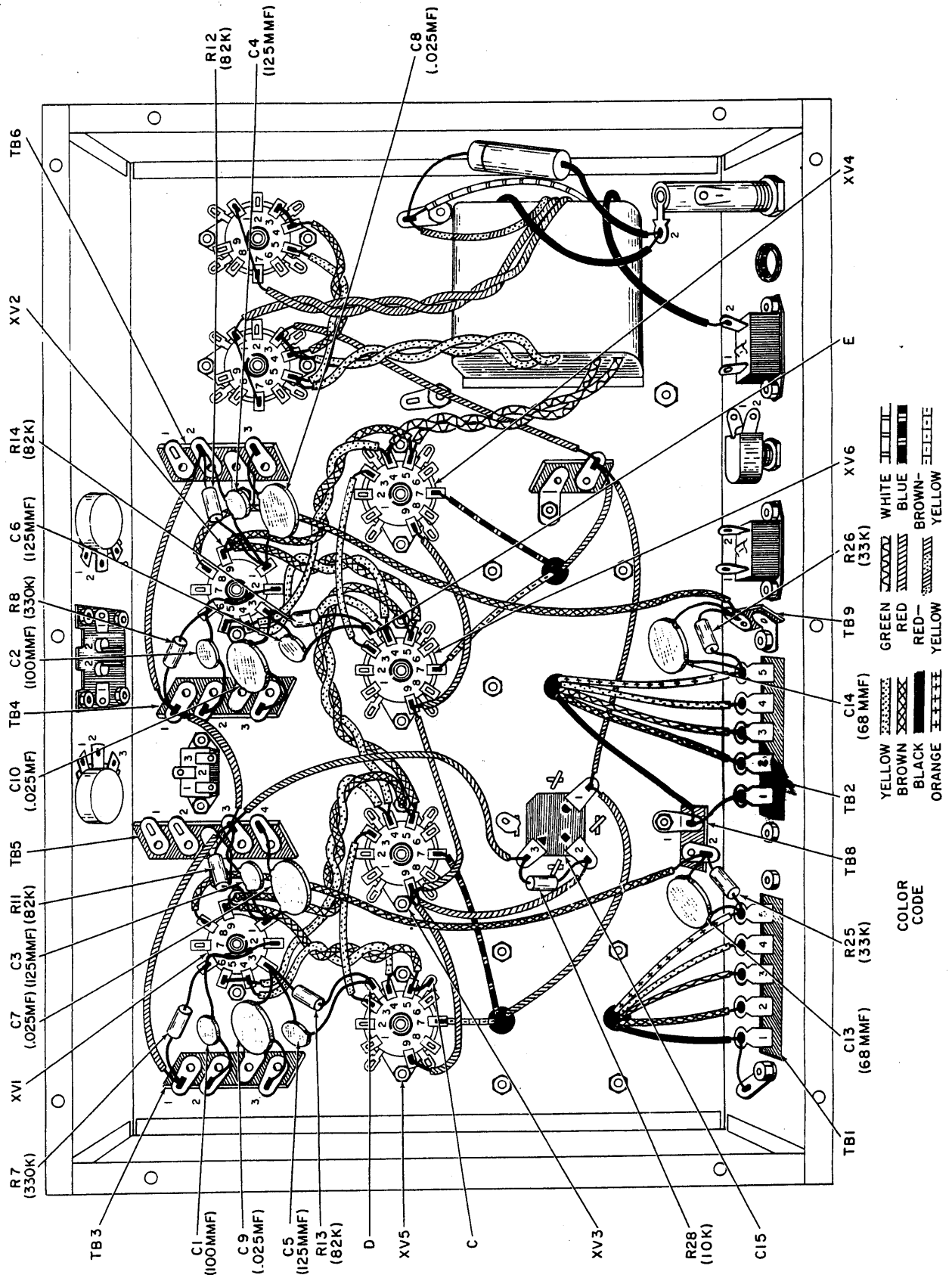

SEE FIGURE 5 FOR ALL STEPS ON THIS PAGE

- (\*) 1. Connect one end of a 3 in. yellow wire to XV2-4. Take a 3 in. brown wire and connect one end to XV2-9. Twist the wires together. Connect the other end of the yellow wire to XV6-4 and the other end of the brown wire to XV6-5. Take a 3/8 in. bare wire and connect XV2-4 to XV2-5. Solder two connections at XV2-9, three at XV2-4, and one at XV2-5.
- (\*) 2. Connect one end of a 4 in. yellow wire to XV6-4. Connect one end of a 4 in. brown wire to XV6-5. Twist the wires together. Connect the other end of the yellow wire to XV3-4 and the other end of the brown wire to XV3-5. Solder two wires connected to XV6-4 and two wires to XV6-5.
- (\*) 3. Connect a 4 in. yellow wire to XV3-4. Take a 4 in. piece of brown wire and connect one end to XV3-5. Twist the leads together. Connect the other end of the yellow wire to XV1-4 and the other end of the brown wire to XV1-9. Solder two wires to XV3-4 and two wires to XV3-5.
- (\*) 4. Connect a 3/8 in. bare wire from XV1-4 to XV1-5. Connect a 3 in. yellow wire to XV1-4 and a 3 in. brown wire to XV1-9. Twist the wires together and connect the other end of the yellow wire to XV5-4 and the other end of the brown wire to XV5-5.
- (\*) 5. Connect a 1/2 in. bare wire from XV5-5 to ground lug C, the ground lug on XV5 closest to pin 5. Solder the connection to the ground lug, two wires connected to XV5-5 and one to XV5-4. Move the iron to XV1 and solder a connection at XV1-5, three at XV1-4, and two at XV1-9.
- (\*) 6. Connect a 4 in. yellow wire from XV5-3 to XV3-3. Connect another 4 in. yellow wire from XV6-3 to XV4-3. Solder the connection at XV6-3.
- (\*) 7. Take three 4 in. red wires, and connect one from XV5-9 to XV3-9, the second from XV3-9 to XV6-9, and the third from XV6-9 to XV4-9. Using a 4-1/2 in. red wire, connect XV3-9 to C15-2. Solder three connections at XV3-9, one at XV5-9, and one connection at XV4-9.
- (\*) 8. Connect an 8 in. piece of brown wire from XV1-8 to TB8-2. Connect another 8 in. piece of brown wire from XV2-8 to TB9.
- (\*) 9. Cut both leads on 68 mfmf disc capacitor C13 to 3/4 in. Connect C13 from TB1-5 to TB8-2.
- (\*) 10. Cut both leads on 33K resistor (orange, orange, orange, and gold bands) R25, to 3/4 in. and connect the resistor from TB1-5 to TB8-2. Now solder three connections made at TB1-5 and three made at TB8-2.
- (\*) 11. Cut both leads on 68 mfmf disc capacitor C14 to 3/4 in. and connect the capacitor from TB2-5 to TB9.
- (\*) 12. Cut both leads on 33K resistor (orange, orange, orange, and gold bands) R26, to 3/4 in. and connect the resistor from TB2-5 to TB9. Solder three connections made to TB2-5 and three made to TB9.
- (\*) 13. Take three 3 in. pieces of red wire and connect one from TB3-1 to TB5-3, a second from TB5-3 to TB4-1, and the third from TB4-1 to TB6-2. Connect a 5 in. red wire from TB5-3 to C15-3.
- (\*) 14. Cut the leads on 10K resistor (brown, black, orange, and silver bands) R28, to 1/2 in. and connect it from C15-2 to C15-3. Solder two connections made at C15-2 and two made at C15-3.
- (\*) 15. Cut the leads on two 125 mfmf capacitors C3 and C4, to 3/4 in. Connect C3 from XV1-1 to TB5-3. Connect C4 from XV2-1 to TB6-2.
- (\*) 16. Cut the leads on two 82K resistors (gray, red, orange, and gold bands) R11 and R12, to 1/2 in. Connect R11 from XV1-1 to TB5-3. Connect R12 from XV2-1 to TB6-2. Solder three connections at TB6-2 and five at TB5-3.
- (\*) 17. Cut the leads on two .025 mfd (25K or 25, mfmf) capacitors C7 and C8, to 1/2 in. Connect C7 from XV1-1 to TB5-4. Connect C8 from XV2-1 to TB6-3. Solder three connections at XV1-1 and three at XV2-1.
- (\*) 18. Cut two 1 in. pieces of bare wire and cover each piece with 3/4 in. of spaghetti. Connect one piece between XV1-2 and XV1-6. Connect the other piece of bare wire between XV2-2 and XV2-6. Solder the connection at XV1-2 and the connection at XV2-2.
- (\*) 19. Cut the leads on two .025 mfd (25K or 25, 000 mfmf) capacitors C9 and C10, to 3/4 in. Connect C9 from XV1-3 to TB3-3. Connect C10 from XV2-3 to TB4-3.
- (\*) 20. Take two 82K resistors (gray, red, orange, and gold bands) R13 and R14 and cut the leads on each to 3/4 in. Connect R13 from XV1-3 to ground lug D on XV5. Connect R14 from XV2-3 to ground lug E on XV6.
- (\*) 21. Cut the leads on each of two 125 mfmf capacitors C5 and C6, to 3/4 in. Connect C5 from XV1-3 to ground lug D. Connect C6 from XV2-3 to ground lug E. Solder three connections made at XV1-3, two at ground lug D, three at XV2-3, and two at ground lug E.
- (\*) 22. Cut the leads on each of two 100 mfmf capacitors C1 and C2, to 1/2 in. Connect C1 from XV1-6 to TB3-2. Connect C2 from XV2-6 to TB4-2.
- (\*) 23. Cut the leads on each of two 330K resistors (orange, orange, yellow and silver bands) R7 and R8, to 1/2 in. Connect R7 from XV1-6 to TB3-1. Connect R8 from XV2-6 to TB4-1. Solder three connections at XV1-6 and three connections at XV2-6.



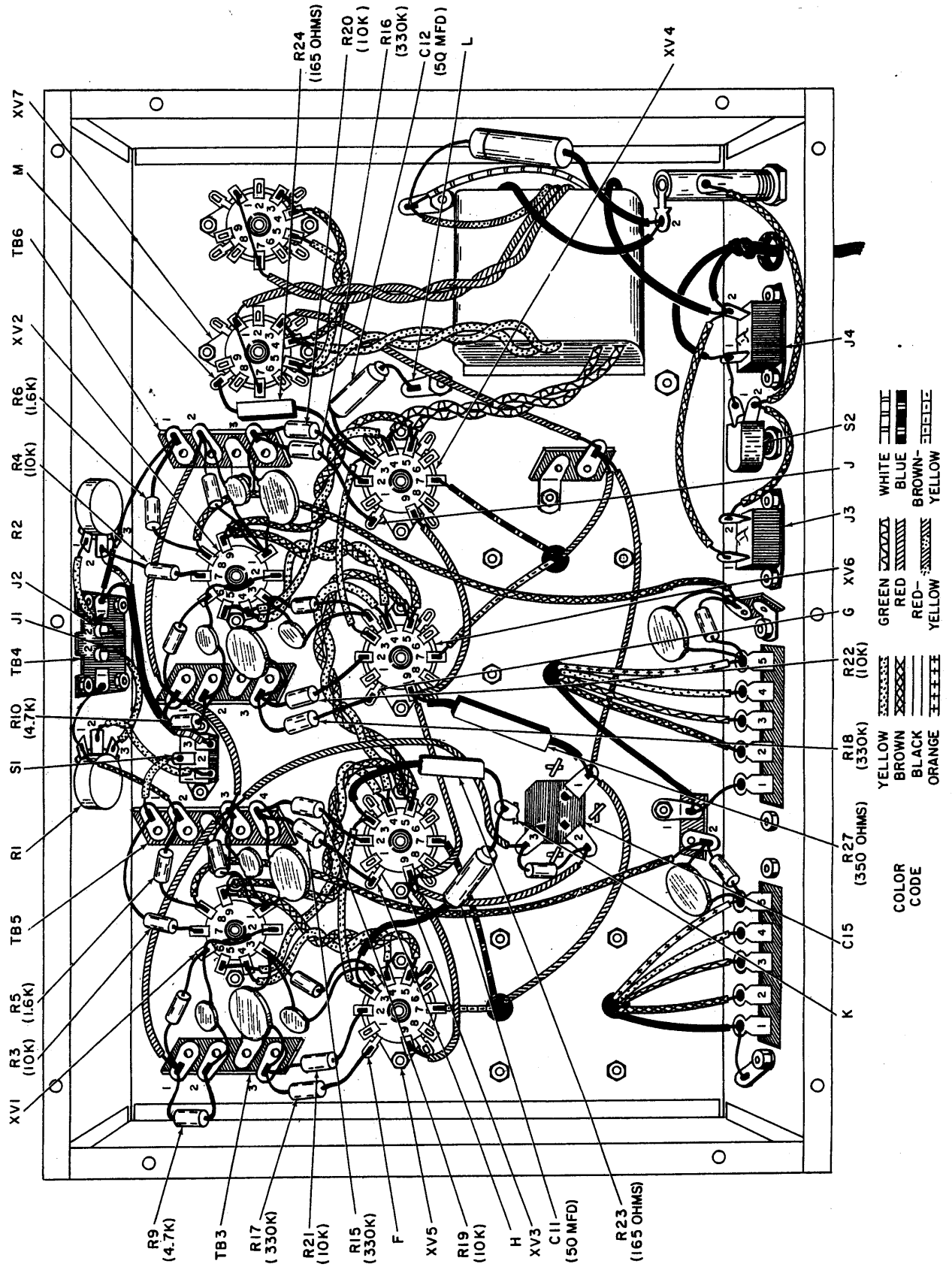

COLOR CODE

YELLOW	GREEN	WHITE
BROWN	RED	BLUE
BLACK	RED-	BROWN-
ORANGE	YELLOW	YELLOW

SEE FIGURE 6 FOR ALL STEPS ON THIS PAGE

- (1) 1. Cut the leads on two 4.7K resistors (yellow, violet, red, and silver bands) R9 and R10, to 1/2 in. Connect R9 from TB3-1 to TB3-2. Connect R10 from TB4-1 to TB4-2. Solder three connections at TB3-1 and two at TB3-2. Solder four connections at TB4-1 and two at TB4-2.
- (1) 2. Take two 10K resistors (brown, black, orange, and silver bands) R3 and R4, and cut one lead on each to 1/2 in. Cut the other lead one each to 1 in. Connect the short lead on R3 to XV1-7 and the long lead to TB5-1. Connect the short lead on R4 to XV2-7 and the long lead to R2-2. Solder one connection made to XV1-7 and one made at XV2-7.
- (1) 3. Cut the leads on each of two 1600 ohm resistors (black, blue, red, and gold bands) R5 and R6, to 1/2 in. Connect R5 from XV1-8 to TB5-2. Connect R6 from XV2-8 to TB6-1. Solder two connections made at XV1-8 and two connections made at XV2-8.
- (1) 4. Connect a 3 in. piece of brown wire from TB5-2 to R1-1, and a 2 in. piece of yellow wire from TB5-1 to S1-2. Solder two connections made at TB5-2, two at TB5-1, and the connection at S1-2.
- (1) 5. Connect a 2 in. yellow wire from switch terminal S1-1 to R1-2. Connect a 1 in. piece of bare wire from J1-1 to R1-1. Solder the connection made at S1-1, J1-1, R1-2, and two connections made at R1-1.
- (1) 6. Take a 1 in. piece of yellow wire and connect it from J1-2 to R1-3. Solder each connection made to J1-2 and R1-3.
- (1) 7. Cut a 1 in. bare wire and cover it with 5/8 in. of spaghetti. Connect one end to J2-1 and the other end to R2-3. Take a 4 in. shielded cable and connect the inner conductor at the end without the shield showing, to S1-3. At the other end of the cable, connect the shield to J2-1 and the center conductor to R2-2. Solder one wire to S1-3, two to J2-1, and two connected to R2-2.
- (1) 8. Connect a 3/4 in. bare wire from R2-3 to TB6-1, and a 1 in. yellow wire from R2-1 to J2-2. Solder two connections at R2-3, two connections at TB6-1, the connection at R2-1, and the connection at J2-2.
- (1) 9. Cut the leads on two 330K resistors (orange, orange, yellow, and silver bands) R17 and R18, to 1/2 in. Connect R17 from TB3-3 to ground lug F on XV5. Connect R18 from TB4-3 to ground lug G on XV6.
- (1) 10. Cut the leads on two 10K resistors (brown, black, orange, and silver bands) R21 and R22, to 1/2 in. Connect R21 from TB3-3 to XV5-2 and connect R22 from TB4-3 to XV6-2. Solder three connections made to

- TB3-3, three connections made to TB4-3, the connection made to ground lug F and ground lug G, and the connection made to XV5-2 and XV6-2.
- (1) 11. Take two 330K resistors (orange, orange, yellow, and silver bands) R15 and R16, and cut the leads on each to 1/2 in. Connect R15 from TB5-4 to ground lug H on XV3. Connect R16 from TB6-3 to ground lug J on XV4. Solder the connection made to ground lug J and ground lug H.
- (1) 12. Cut the leads on two 10K resistors (brown, black, orange, and silver bands) R19 and R20 to 1/2 in. Connect R19 from TB5-4 to XV3-2. Connect R20 from TB6-3 to XV4-2. Now solder three connections made at TB5-4, three at TB6-3, the connection to XV4-2, and the one at XV3-2.
- (1) 13. Take two electrolytic 50 mfd capacitors C11 and C12, and cut the leads on each to 1-1/4 in. Cover the leads on the capacitors with 1 in. of spaghetti. Connect the lead on the positive (+) end of capacitor C11 to XV5-3. Connect the lead on the negative (-) end of this capacitor to ground lug K. Connect the lead on the positive (+) end of capacitor C12 to XV4-3. Connect the lead on the negative (-) end of C12 to ground lug L. Solder two connections made to XV5-3 and one made to ground lug L.
- (1) 14. Cut the leads on two 165 ohm wire wound resistors R23 and R24 to 1 in. and cover each lead with 3/4 in. of spaghetti. Now connect R23 from XV3-3 to ground lug K and connect R24 from XV4-3 to ground lug M on XV7. Solder two connections made to XV3-3 and two connections made to ground lug K. Solder three connections made to XV4-3, and the one to ground lug M on XV7.
- (1) 15. Cut the leads on 350 ohm wire wound resistor R27 to 1 in. Cover each lead with 3/4 in. of spaghetti. Connect the resistor from XV6-9 to C15-1. Solder three connections made to XV6-9 and three to C15-1.
- (1) 16. Connect a 4 in. piece of brown wire from J3-1 to J4-2, and a 1 in. piece of bare wire from toggle switch terminal S2-1 to J4-1. Solder the connection at J3-1 and the connection at S2-1.
- (1) 17. Connect a 2 in. brown wire from J3-2 to S2-2 and a 4 in. brown wire from S2-2 to XF1-1. Solder the connection made to J3-2, the connection made to XF1-1, and two connections made to S2-2.
- (1) 18. Feed the tinned leads of the power line cord from outside the chassis through the grommet in the rear apron of the chassis. Tie a knot in the line cord 2 in. from the tinned leads, so that the cord cannot pull through the grommet. Connect one lead to J4-1 and the other lead to J4-2. Now solder two connections made at J4-1 and three connections made at J4-2.

## FINAL STEPS

You have now completed the assembly and wiring of your amplifier. When you have completed the following steps your amplifier will be ready for use.

- ( ) 1. To catch any wiring errors, it is suggested that the entire wiring be checked point-by-point against the wiring instructions (and preferably also against the schematic wiring diagram in order to become more familiar with the component layout and circuitry). While doing so, check for rosin joints, loose lumps of solder, poor lead dress, and accidental shorts or leakage paths arising from the flow of rosin between contacts (remove with a stiff brush dipped in carbon tetrachloride, being careful not to inhale fumes or to contact the carbon tetrachloride with your skin).
- (✓) 2. Insert tubes V1 through V8 in their sockets. Be sure to insert the correct tube in each socket. Place a shield over tubes V1 and V2. Insert fuse F1 in fuseholder. **DO NOT PLUG POWER CORD INTO POWER LINE.**
- (✓) 3. If you have a VTVM or VOM, make the following resistance checks before connecting to the a-c line: Check for a cold d-c resistance of at least 1/2 ohm across the a-c line plug; check for a resistance of at least 30 ohms between ground and pins 1 of XV7 and XV8; check for a resistance of at least 200K $\Omega$  between pin 3 of XV7 and ground. Allow sufficient time for the electrolytic capacitors to be charged by the ohmmeter battery in this last measurement. These measurements constitute a reasonable check of the power supply components and wiring before applying power. If you do not obtain the minimum resistance values indicated, do not proceed to the next step until the cause is discovered and the condition remedied.
- (✓) 4. Press a No. 8 tinnerman speed nut in place over each hole on the bottom flange of the chassis. (See figure 7.)
- (✓) 5. If the amplifier is not going to be fastened to some surface, insert the rubber feet in the openings provided in the bottom plate and mount the bottom plate of the chassis, using 10 No. 8-32 screws. If the amplifier is to be fastened to a surface, the feet will not be used and the bottom plate will be required as a template before it is attached to the amplifier.

- ( ) 6. Read the MECHANICAL INSTALLATION and ELECTRICAL INSTALLATION sections of the instruction book carefully, and install and connect the amplifier according to the information given.

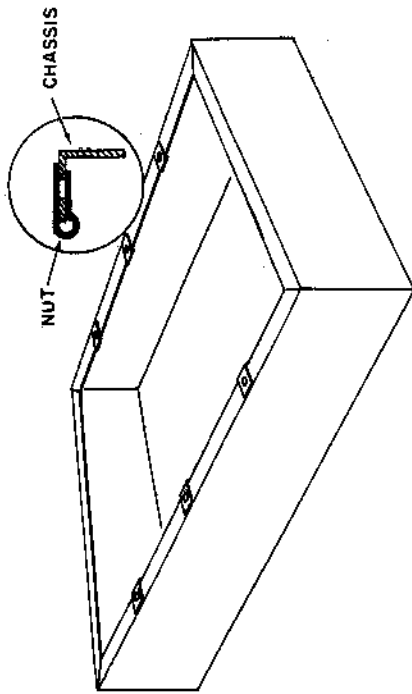

Figure 7. Location of Bottom Plate Speed Nuts

## SERVICE

If you are still having difficulty, write to our service department listing all possible indications that might be helpful. If desired, you may return the instrument to our factory where it will be placed in operating condition for \$7.50 plus the cost of parts replaced due to their being damaged in the course of construction. This service policy applies only to completed instruments constructed in accordance with the instructions as stated in the manual. Instruments that are not completed or instruments that are modified will not be accepted for repair. Instruments that show evidence of acid core solder or paste fluxes will be returned not repaired. NOTE: Before returning this unit, be sure all parts are securely mounted. Attach a tag to the instrument, giving your home address and the trouble with the unit. Pack very carefully in a rugged container, using sufficient packing material (cotton, shredded newspaper, or excelsior), to make the unit completely immovable within the container. The original shipping carton is satisfactory, providing the original inserts are used or sufficient packing material is inserted to keep the instrument immovable. Ship by prepaid Railway Express, if possible, to the Electronic Instrument Co., Inc., 33-00 Northern Blvd., L.I.C. 1, New York. Return shipment will be made by express collect. Note that the carrier cannot be held liable for damages in transit if packing, IN HIS OPINION, is insufficient.

# HARDWARE ITEMS

ACTUAL DIAMETERS

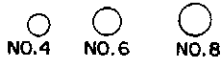

NO. 4 NO. 6 NO. 8

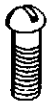

No. 6-32 X 3/8 ROUND HEAD MACHINE SCREW (RHMS)  
 LENGTH OF SCREW  
 THREADS TO THE INCH  
 DIAMETER OF SCREW



No. 6 FLAT WASHER



No. 6 LOCK WASHER



No. 6 HEX NUT



No. 8-32 X 3/8 BINDING HEAD MACHINE SCREW (BHMS)



No. 8 FLAT WASHER



No. 8 SOLDER LUG



No. 8 HEX NUT



No. 8-32 X 3/8 FILISTER HEAD MACHINE SCREW (FHMS)



No. 8 SET SCREW



SPEED NUT (tinnerman)



FLAT FIBER WASHER



CONTROL SHAFT WASHER 3/8



CONTROL SHAFT HEX NUT 3/8

## GROMMETS



## TUBE SOCKET RETAINERS



## TERMINAL STRIPS

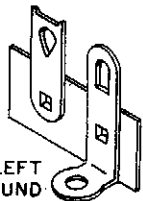

ONE POST LEFT  
WITH GROUND

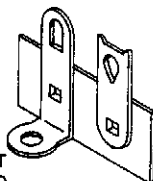

ONE POST RIGHT  
WITH GROUND

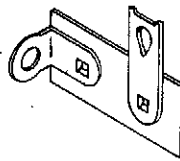

UPRIGHT  
ONE POST LEFT

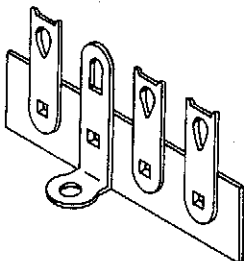

THREE POST  
2 RIGHT  
WITH GROUND

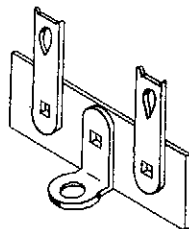

TWO POST

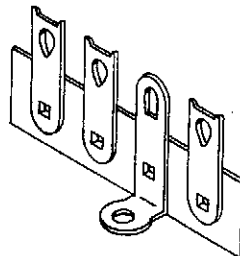

THREE POST  
2 LEFT  
WITH GROUND

# RESISTOR COLOR CODES

RMA COLOR CODE FOR FIXED COMPOSITION RESISTORS

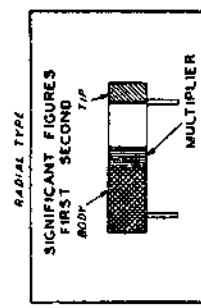
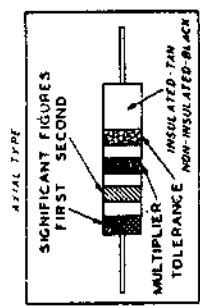

JAN COLOR CODE FOR FIXED COMPOSITION RESISTORS

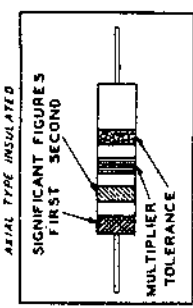

RADIAL TYPE NON-INSULATED

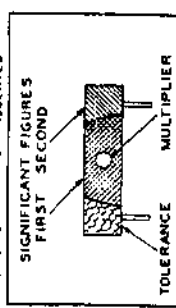

# CAPACITOR COLOR CODES

JAN 6-DOT COLOR CODE FOR PAPER-DIELECTRIC CAPACITORS

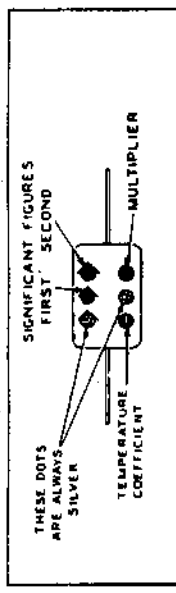

JAN 6-DOT COLOR CODE FOR MICA-DIELECTRIC CAPACITORS

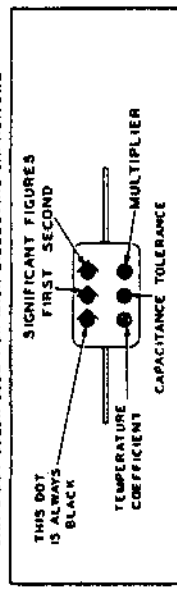

JAN COLOR CODE FOR FIXED CERAMIC-DIELECTRIC CAPACITORS

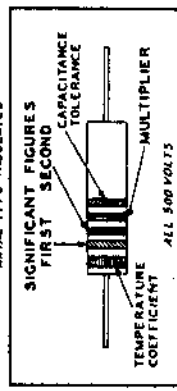

RMA 3-DOT COLOR CODE FOR MICA-DIELECTRIC CAPACITORS

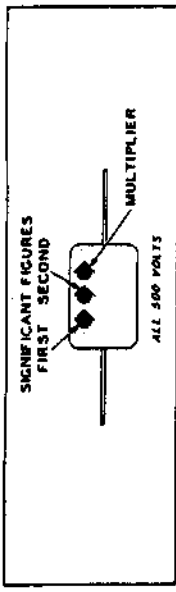

RMA 6-DOT COLOR CODE FOR MICA-DIELECTRIC CAPACITORS

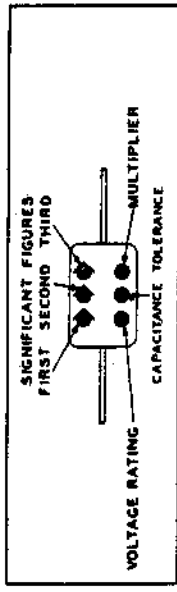

RMA COLOR CODE FOR TUBULAR CERAMIC-DIELECTRIC CAPACITORS

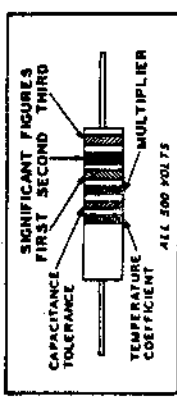

RMA: RADIO MANUFACTURERS ASSOCIATION  
JAN: JOINT ARMY-NAVY

RESISTORS		CAPACITORS						
TOLERANCE	MULTIPLIER	SIGNIFICANT FIGURE	COLOR	RMA MICA AND CERAMIC-DIELECTRIC	JAN MICA AND PAPER-DIELECTRIC	JAN CERAMIC DIELECTRIC	VOLTAGE RATING	TEMPERATURE COEFFICIENT
1	1	0	BLACK	1	1	1	A	
10	10	1	BROWN	10	10	10	B	
100	100	2	RED	100	100	100	C	
1000	1000	3	ORANGE	1000	1000	1000	D	
10000	10000	4	YELLOW	10000	10000		E	
100000	100000	5	GREEN	100000			F	
1000000	1000000	6	BLUE	1000000			G	
10000000	10000000	7	VIOLET	10000000				
100000000	100000000	8	GRAY	100000000		0.01		
5	0.1	9	WHITE	0.1	0.1	0.1		
10	0.01		GOLD	0.01	0.01			
20			SILVER					
			NO COLOR					

## VOLTAGE AND RESISTANCE CHART

TUBE	PIN#	DC VOLTS NO SIGNAL	DC VOLTS 14 WATTS	AC VOLTS (1 kc) 1.25 VOLTS INPUT	RESISTANCE, $\Omega$ UNIT OFF
12DW7/7247 V1, V2	1	200	190	6.7	82K
	2	95	90	7.6	340K
	3	102	97	6.7	82K
	4&5	filament (6.3VAC to pin 9)			
	6	95	90	7.6	340K
	7	0	0	1	510K
	8	1	.95	.9	1.6K
	9	filament			
	EL84/7189/6BQ5 V3, V4, V5, V6	1	0	0	6.7
2		0	0	6.7	340K
3		13	17	.05	165 $\Omega$
4&5		filament (6.3VAC between pins 4&5)			
6		-	-	-	-
7		335	325	178	210 $\Omega$
8		-	-	-	-
9		330	320	1.3	350 $\Omega$
EZ81/6CA4 V7, V8		1	-	-	290*
	2	-	-	-	-
	3	343	335	7.6*	100K**
	4&5	filament (6.3VAC between pins 4&5)			
	6	-	-	-	-
	7	-	-	290*	60
	8	-	-	-	-
	9	-	-	-	-

\*60 cycles

\*\*Min. value. May take 5 minutes to reach this value with lead connected to pin.

Service Sel Sw is in combined position. For test with signal, use one load resistor across each speaker output terminal strip. All voltages and resistances are measured with a high input impedance VTVM. All resistance measurements are made with pin 3 of the EZ81 (both) grounded except, of course, when the resistance to ground at pins 2 and 8 of the EZ81 is being checked. Operating line voltage at which voltage measurements are made is 117 volts AC, 60 cps. NOTE: ALL VOLTAGE & RESISTANCE VALUES MAY VARY NORMALLY BY  $\pm 1.5\%$ .

## TROUBLE-SHOOTING PROCEDURES

SYMPTOM	CAUSE	REMEDY
House power line fuse blows; fuse, F1, remains intact.	Short in line cord, J3, J4 or associated equipment plugged into J3 or J4.	Repair
Fuse, F1, blows.	If the amplifier causes a replacement fuse to blow with rectifier tubes V7 and V8 removed, primary or high voltage secondary windings of T3 are incorrectly wired or shorted.	Check and repair or replace.
	If F1 does not blow after replacement (with V7 and V8 removed), check for short in B+ circuits, defective V7 or V8 and C15.	Check and repair or replace.
Any or all tube filaments not lit.	Open lead from 6.3V winding of T3. 6.3V winding of T3 open.	Repair Replace T3.
DC voltage at V7 or V8 cathode (pin 3) is incorrect as specified below.		
a) No voltage	Defective V7 or V8. C15 shorted internally or externally. Connection to C15 broken.	Replace Replace or repair. Repair
b) High voltage	Connection to center tap of h.v. sec. winding of T3 open. Output tubes V3 and V4 or V5 and V6 over-biased or not drawing current.	Repair See trouble-shooting typical stage.
c) Low voltage	Excessive current drain in amplifier. Defective V7 or V8	See trouble-shooting typical stage. Replace.

## REPLACEMENT PARTS LIST

Stock #	Symbol	Description	Am't.
✓ 22509	C1, 2	cap., disc, 100mmf, ±10%	2 ✓
✓ 22545	C3, 4, 5, 6	cap., disc, 125mmf, ±10%	4 ✓
✓ 22517	C7, 8, 9, 10	cap., disc, .025mfd, GMV (25, 000 or 25K)	4 ✓
✓ 23007	C11, 12	cap., elec., 50mfd, 25V	2 ✓
✓ 22534	C13, 14	cap., disc, 68mmf, ±10%	2 ✓
✓ 24011	C15	cap., elec., 30-20-20mfd, 450V	1 ✓
✓ 20043	C16	cap., molded, .03mfd, 600V	1 ✓
✓ 91005	F1	fuse, 3 AMP	1 ✓
✓ 50011	J1-2	jack, dual input	1 ✓
✓ 50016	J3, 4	outlet, convenience	2 ✓
✓ 18050	R1, 2	pot., 500KΩ, slotted shaft, audio taper	2 ✓
✓ 10400	R3, 4, 19, 20 21, 22, 28	res., 10KΩ, 1/2W, ±10% (brown, black, orange, silver)	7 ✓
✓ 11542	R5, 6	res., 1.6KΩ, 1/2W, ±5% (brown, blue, red, gold)	2 ✓
✓ 10412	R7, 8, 15, 16 17, 18	res., 330KΩ, 1/2W, ±10% (orange, orange, yellow, silver)	6 ✓
✓ 10430	R9, 10	res., 4.7K, 1/2W, ±10% (yellow, violet, red, silver)	2 ✓
✓ 11547	R11, 12, 13, 14	res., 82K, 1/2W, ±5% (grey, red, orange, gold)	4 ✓
✓ 14600	R23, 24	res., 165Ω, 5W, ±5%	2 ✓
✓ 11546	R25, 26	res., 33K, 1/2W, ±5% (orange, orange, orange, gold)	2 ✓
✓ 14302	R27	res., 350Ω, 10W, ±5%	1 ✓
✓ 62002	S1	switch, slide, SPDT	1 ✓
✓ 61000	S2	switch, toggle SPST	1 ✓
✓ 32013	T1, 2	transformer, output	2 ✓
✓ 30021	T3	transformer, power	1 ✓
✓ 54516	TB1, 2	terminal board, 5 screw	2 ✓
✓ 54006	TB3, 4	terminal strip, 3 post, 2 right	2 ✓
✓ 54008	TB5	terminal strip, 4 post	1 ✓
✓ 54014	TB6	terminal strip, 3 post, 2 left	1 ✓
✓ 54001	TB7	terminal strip, 1 post, right	1 ✓
✓ 54002	TB8	terminal strip, 1 post, right w/gnd	1 ✓
✓ 54000	TB9	terminal strip, 1 post, right, upright	1 ✓
✓ 90061	V1, V2	tube, 12DW7/7247	2 ✓
✓ 90039	V3, 4, 5, 6	tube, EL84/6BQ5/7189	4 ✓
✓ 90038	V7, 8	tube, EZ81/6CA4	2 ✓
✓ 97800	XF1	fuseholder	1 ✓
✓ 97025	XV1, 2	socket, 9 pin min., top mount	2 ✓
✓ 97027	XV3, 4, 5, 6, 7, 8	socket, 9 pin min., bottom mount	6 ✓
40000		nut, hex, 6-32	14
✓ 40001		nut, hex, 3/8-32	2 ✓
✓ 40002		nut, hex, 15/32-32	1 ✓
✓ 40003		nut, ring, 15/32-32	1 ✓
40007		nut, hex, 4-40	22
40008		nut, hex, 8-32	12
40016		nut, hex, 1/2" (fuseholder)	1
40017		nut, Tinnerman #8	10 ✓
✓ 41003		screw, #8-32 x 3/8	18 ✓
41014		screw, #6-32 x 3/8	14
41016		screw, #4-40 x 1/4	22
41028		screw, #8-32 x 1	4
✓ 42000		washer, lock, 3/8	2 ✓
42002		washer, lock, #6	14
42007		washer, lock, #4	22
42008		washer, lock, #8	10
42029		washer, flat, rubber 1/2" (fuseholder)	1
43000		ground lug #6	1
✓ 43004		ground lug #8	2 ✓
✓ 46000		grommet 3/8 rubber	1 ✓
✓ 46006		feet, rubber	4 ✓
✓ 51006		plug, RCA phono	2 ✓
✓ 57000		line cord	1 ✓
✓ 58004		wire, hookup, #22 solid	length ✓
✓ 58300		spaghetti	length ✓
✓ 58408		cable, single conductor	length ✓
✓ 58501		wire, bare #22	length ✓
✓ 81097		bottom plate	1 ✓
✓ 81180		chassis	1 ✓
✓ 97300		tube shield	2 ✓

