



Acousta-Master

AMPLIFIERS

Models CT 35/60/100

Bogen **Acousta-Master**® CT Series Public Address Amplifiers are versatile, silicon-transistor preamp-mixer-amplifiers designed for professional-quality sound reinforcement requirements. Model CT-35 is rated at 35 watts, Model CT-60 at 60 watts and CT-100 at 100 watts output.

Four high-impedance microphone inputs are provided, each convertible for use with low-impedance microphones. A simple modification converts inputs to low-impedance unbalanced; balanced inputs require accessory plug-in transformers. Two mic inputs and one auxiliary input may be remotely controlled or muted for announcements over another mic channel. The same two mic inputs may be converted to accept a magnetic source, i.e., turntable or tape player. Two auxiliary inputs with fader control are provided, as well as a bridging input.

Acousta-Master amplifiers feature the Bogen built-in acoustic equalizer filter circuit, which provides a means of boosting or attenuating any of five selected frequencies to suit individual room acoustics. An electronic limiter circuit provides uniform output regardless of wide variations in the input level. With this capability, all paging calls can be transmitted with the same volume and clarity.

An output terminal strip and connectors at the rear of the amplifier provide standard speaker impedance taps, as well as connections for 25-volt or 70-volt balanced lines. There is also a bridging output for feeding a tape recorder.

Bogen accessories provide the amplifier with telephone line input and output connections, remote volume control, and channel override facilities. Further information is contained in the Accessories section.

The amplifier operates from a 105-125 volt, 50/60 Hz source. A three-prong line cord provides automatic grounding when connected to a three-wire power outlet. The power line is protected by a circuit breaker, and the output transistors by a thermal overload device, which shuts off the unit when the temperature of the heat sink rises excessively.

INSTALLATION

UNPACKING

The amplifier was carefully checked before leaving factory. Inspect shipping container and unit carefully for indications of improper handling. If the unit has been damaged, make an immediate claim to distributor from whom it was purchased. If the amplifier was shipped to you, notify transportation company without delay and place your claim.

POWER AND GROUNDING

The ac line cord has a three-prong plug which should be plugged into a three-wire grounded, 120 volt, 60 Hz outlet. As it is important to ground the amplifier, where a three-wire outlet is not available, use an adapter (e.g., Leviton No. 5017) and connect the grounding pigtail to the screw securing the wall plate. If the wall plate screw is not grounded, connect a wire from the GND terminal of the amplifier to a suitable ground.

AUXILIARY POWER

The auxiliary power receptacle on the rear chassis (see figure 1) is a three-wire grounded outlet, which can supply power to accessory sound equipment. When connecting associated equipment with a three-prong cord, appropriate grounding is accomplished when the amplifier line cord is properly grounded.

Use the ON/OFF switch on the phonograph for turning off a record player connected to the auxiliary receptacle, as use of the amplifier power switch could cause flats to develop on the idler wheel of the phonograph.

Be sure that the auxiliary components do not draw more than 250 watts on the CT35 and CT 60, and 500 watts on the CT1 00.

TECHNICAL SPECIFICATIONS

	CT35	CT60	CT100
POWER OUTPUT (RMS at 1000Hz)	35 watts	60 watts	100 watts
	@ less than 2% total harmonic distortion		
FREQUENCY RESPONSE	50Hz to 15kHz \pm 2dB		
REGULATION	2 dB		
HUM & NOISE (below rated output)	MIC, 60 dB for both low and high impedance; AUX 70 dB; Fundamental, 80 dB		
SENSITIVITY (for rated output)	Hi Z MIC, 3 mV; Low Z Bal MIC, 0.3 mV; Low Z Unbal MIC 0.3 mV; Bridging Input, 30 mV; AUX 150 mV		
OUTPUTS	4, 8 16 ohms 25V CT 7ov	8, 16 ohms 25V CT 7ov	4, 8, 16 ohms 25V CT 7ov
	Bridging, 30 mV; Tape, 0.68 V. TAPE/BOOSTER/BRIDGING outputs, 500/600 Ω telephone line input or output with WMT-i optional accessory.		
OUTPUT CONNECTIONS	2 Quick disconnect type sockets with plugs provided, in addition to screw-type terminals, tape/booster jack, and provisions for WMT-1.		
INPUTS	4 Hi Z MIC inputs, each convertible to Low Z Bal or Unbal MIC; 2 AUX inputs with fader control; MIC 1 & 4 convertible to MAG input; Bridging input; 500/600 ohm telephone line with optional WMT-1 accessory; 3 inputs for remote volume control.		
CONTROLS	4 MIC Volume, AUX 1, AUX 2-fader, MASTER VOLUME, 5 Equalizer Filter Slide Controls. 1 Compressor. 1 Power Switch.		
FILTER CONTROL ACTION	\pm 10 dB variation at the following frequencies: 80 Hz, 300 Hz, 1 kHz 3 kHz 10 kHz.		
COMPRESSION	5 milliseconds attack time, 2 seconds decay time, max. compression 30 dB		
LINE FUSING	Resettable Circuit Breaker		
	0.93 A Hold	1.65 A Hold	2.5 A Hold
SEMICONDUCTORS	18 silicon transistors	18 silicon transistors	20 silicon transistors
	2 Zener Diodes; 8 Silicon Diodes (10 in CT100)		
POWER CONSUMPTION	120 V AC, 50/60 Hz		
	0.86A, 96W	1.6A, 170w	2.9A, 300W
DIMENSIONS	16-3/8"W x 12 3/4"D x 4 3/4"H (41.6cm x 32.4cm x 12.1cm)	16-3/8"W x 13 3/4"D x 4 3/4"H (41.6cm x 34.9cm x 12.1cm)	
SHIPPING WEIGHT	19 lbs. (8.6 kg)	22lbs. (9.9 kg)	26 lbs. (11.8 kg)

INPUT CONNECTIONS

HIGH IMPEDANCE MICROPHONES: The amplifier is shipped in a configuration for direct connection of high impedance microphones (50k ohms) to the four MIC input receptacles of the amplifier. The microphone lead should be a single-conductor shielded cable under 35 feet long and terminated in a Cannon XLR-311C connector (Bogen Part No. 85-0124-01) as shown in figure 2.

In the event jumpers on the printed circuit board have been rearranged and must be returned to the configuration for direct connection of high impedance microphones, connect the two jumpers involved as follows: the first jumper between terminals 11 and 19, and the second be-

tween 8 and 18. Three jumpers are not involved and are stored by connecting both ends to an assigned terminal: the first jumper on terminal 20, the second on 24, and the third on 25.

BALANCED LOW-IMPEDANCE MICROPHONES: Low-impedance accessory transformers are required to permit the amplifier to accept inputs from microphones rated from 50 to 600 ohms. Before connecting microphone, insert appropriate plug-in transformers and reset jumpers adjacent to transformer sockets as described in the Accessories section. Use a two-conductor shielded cable for the +microphone lead, terminated in a Cannon XLR-311C connector, as shown in figure 3.

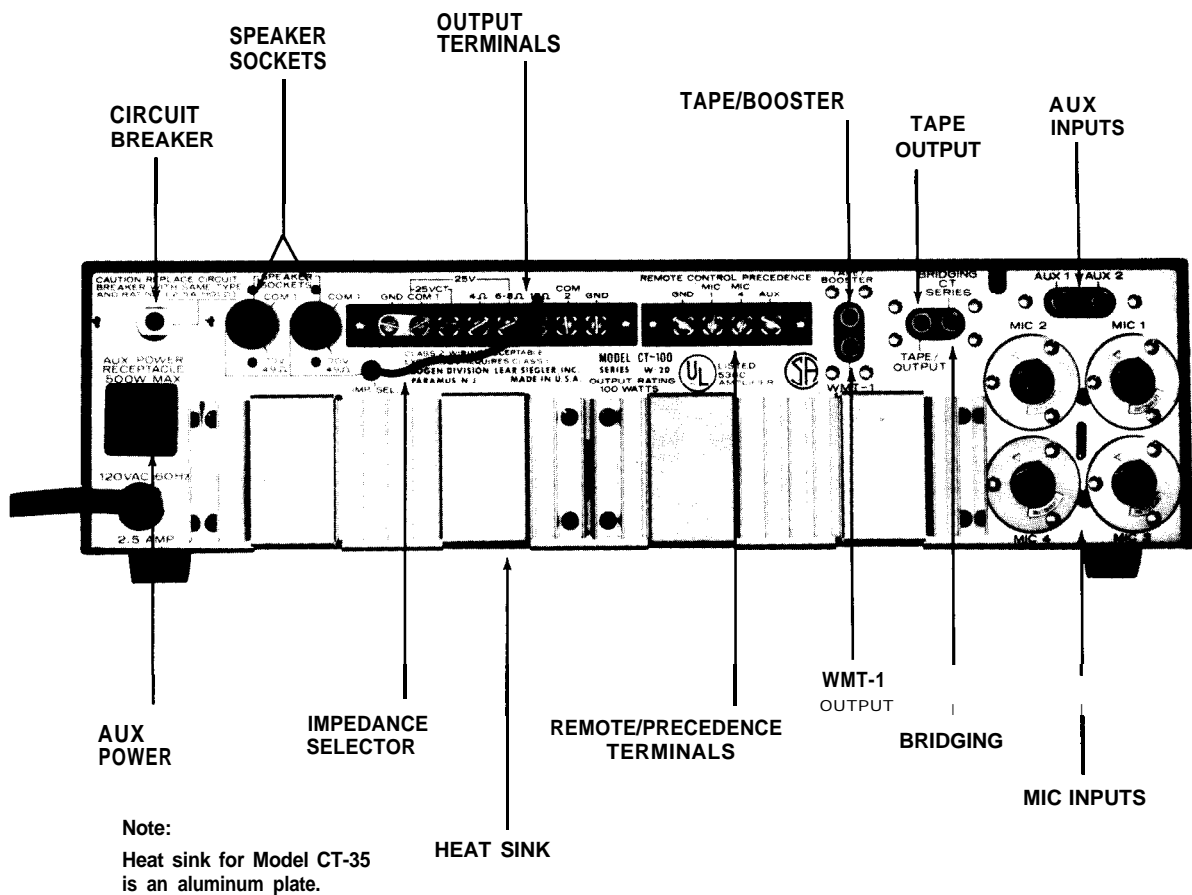

Figure 1 – Rear Panel, CT-100

UNBALANCED LOW IMPEDANCE MICROPHONES:

Jumpers with push-on connector lugs are mounted on the printed circuit board assembly for use in converting the MIC input channel circuits. See note 4 on the schematic diagram, figure 6. To convert MIC 1 and 4 for unbalanced low impedance use, connect jumper between pins 20 and 21; to convert MIC 2 and 3, connect jumper between pins 25 and 26. As shown in figure 2, connect a jumper between terminals 1 and 2 of the connector and wire microphone to pin 3 of the plug.

AUXILIARY INPUTS: Two auxiliary inputs are provided for high-level, high impedance inputs. these may be used to connect a radio tuner, tape recorder, or turntable utilizing a ceramic cartridge. An input signal of 0.15 volts is required to obtain full output from the amplifier.

Use single-conductor shielded cable terminated in an RCA phono plug for connecting auxiliary component. If hum is experienced after making connections, run a ground wire between the chassis of the auxiliary unit and the GND terminal on the amplifier.

BRIDGING: The amplifier may be bridged to a second Bogen CT amplifier to double the number of inputs. Connect a single-conductor shielded cable, terminated in an RCA phono plug at each end, between the rear panel BRIDGING receptacles of the two amplifiers. Any input to either amplifier will then be fed through and available at the output of both amplifiers. The amplifiers must each feed separate speaker systems.

When two amplifiers are bridged together, any adjustment of the MASTER, COMPRESSION or Acoustic Equalizer controls in one amplifier will not affect the output of the other amplifier.

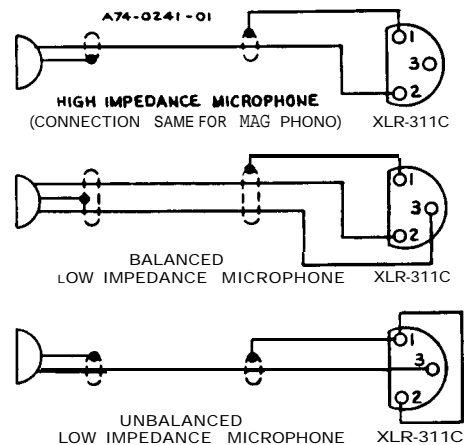

Figure 2 – Connecting Microphone Cable Connector

MAG PHONO: The output of a phonograph employing a magnetic cartridge may be connected to the MIC 1 and 4 receptacles on the rear panel. Use a single-conductor shielded audio cable terminated in a Cannon XLR3 11C connector as shown in figure 2 (connections same as high impedance mic). A magnetic tape head may also be connected in this manner.

To provide the necessary equalization for magnetic phono and tape head inputs, the Berg terminal jumpers on the printed circuit board must be connected as indicated in note 3 on the schematic diagram. Connect a jumper between pins 21 and 22 and between pins 23 and 24.

OUTPUT CONNECTIONS

SPEAKERS: For installations where speakers will be connected permanently, output connections are available on the terminal strip at the rear of the amplifier for 4, 8, and 16 ohm speakers and 25volt lines. Connections may be made for an unbalanced line or for a balanced line with or without center-tap grounding. Make speaker line connections as shown in Table 1.

Impedance indicated in Table 1 is also available at two speaker sockets on the rear panel. Two quick-disconnect plugs (Bogen 85-0147-01) are furnished with the amplifier to make connections to these sockets. Wiring of the speaker output plug is shown in figure 3. When the speaker sockets are used, connect the wired plug to either socket. For unbalanced, 4, 8, 16 ohms and 25-volt operation, attach the impedance selector lead to the speaker system impedance terminal, and leave the link connected between COM 1 and GND terminals. A balanced output is available by removing the link.

For 70 volt constant voltage systems, see Table 1. For detailed information see installation manual No. 54-5001, furnished with the amplifier.

To minimize shock hazard, Class I wiring as defined in local building codes should be used for 70-volt outputs. All other outputs may use Class 2 wiring.

CONNECTING AMPLIFIERS IN SERIES: Pairs of Bogen CT amplifiers of the same power rating can be connected in series to effectively double the power output into the same speakers. See figure 4 for connection diagram. Be certain to remove the link between COM 1 and GND of amplifier No. 2.

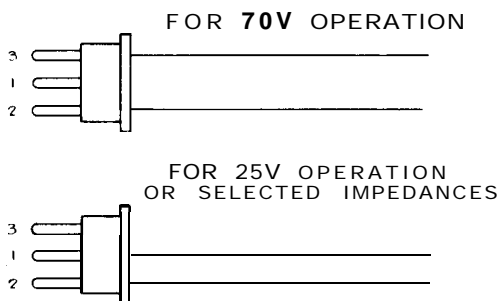

Figure 3-Speaker Output Plug Wiring

Connect a single conductor shielded cable, terminated in an RCA phono plug at each end, between the rear panel BRIDGING receptacles of both amplifiers. This assures that any input will have equal amplification.

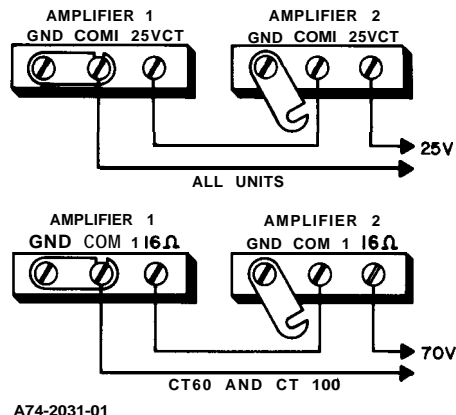

Figure 4 - Connecting Amplifiers in Series

Both amplifier tone and master volume controls must be at the same setting to assure that each amplifier will share the load equally.

TAPE/BOOSTER OUTPUT: The amplifier may be used to drive a tape recorder or a booster amplifier. Connect a patch cord with an RCA phono plug from the TAPE/BOOSTER jack on the rear panel of the amplifier to the input of the tape recorder or booster amplifier. The output at this jack is controlled by the amplifier's volume and equalization controls.

TAPE OUTPUT: A tape recorder may also be driven from the TAPE OUTPUT jack on the amplifier. In this case, the output is not subject to the master volume and equalization settings of the amplifier and is controlled at the tape recorder. A patch cord terminated in an RCA phono plug is connected between the TAPE OUTPUT jack on the amplifier and the input of the tape recorder.

WMT-1 OUTPUT: This receptacle is used to accommodate a Bogen accessory which provides connections to a 500/600-ohm telephone line.

ACOUSTIC EQUALIZER: The Acoustic Equalizer permits you to "tune" the amplifier to the room in which the sound system is used, so that the amplifier will operate at a substantially higher output before acoustic feedback occurs. Five slide controls, located on the front panel, boost or attenuate the output at five selected frequencies-80 Hz, 300 Hz, 1 KHz, 3 kHz, and 10 kHz. Varying room acoustics or microphone placement may cause feedback or howling at or near some of these frequencies. If so, feedback can be greatly attenuated by setting the slide control for that particular frequency as described below.

TARIF 1—OUTPUT CONNECTIONS

Models	Speaker Line	Terminal Connections *	Other Connections
CT35 & CT100	4Ω Unbalanced	4Ω and COM 1	Close link between COM 1 and GND
	4Ω Balanced	4Ω and COM 1	Open link between COM 1 and GND
All models	8Ω Unbalanced	8Ω and COM 1	Close link between COM 1 and GND
	8Ω Balanced	8Ω and COM 1	Open link between COM 1 and GND
All	16Ω Unbalanced	16Ω and COM 1	Close link between COM 1 and GND
	16Ω Balanced	16Ω and COM 1	Open link between COM 1 and GND
All	25V Unbalanced	25V and COM 1	Close link between COM 1 and GND
	25V Balanced	25V and COM 1	Open link between COM 1 and GND
	25V Balanced, CT gnd.	25V and COM 1	Connect jumper between 25V CT and GND
			Open link between COM 1 and GND
	70V Unbalanced	Pins 2 and 3	Connect impedance selector to COM 2
All	70V Balanced	Pins 2 and 3	Connect jumper between COM 2 and GND Connect impedance selector to COM 2

**Also see text under "Output Connections"*

ROOM EQUALIZATION: With speakers connected and one microphone in normal operating location, turn amplifier on and proceed as follows:

1. Connect microphone to appropriate MIC input of amplifier.
2. Set all five acoustic filter controls to zero (center position).
3. Turn MIC volume control half-way up and the three other MIC volume controls to zero.
4. Advance MASTER volume control slowly until feedback is heard.
5. Note the frequency of the feedback tone, and determine which of the five selected frequencies on the Acoustic Equalizer is closest to it.
6. Move the control determined in Step 5, above, down toward minimum until feedback disappears.
7. Advance MASTER control again and note whether feedback is heard at another frequency.
8. Adjust the appropriate filter controls until this feedback disappears.
9. Continue to advance MASTER control and adjust individual filter controls until MASTER control is at maximum setting, consistent with a stable output without feedback at any frequency.
10. Output level reduced because of attenuating one frequency may be partly restored by boosting the adjacent frequency filter control toward maximum.

If feedback is not a problem, the controls should be used to improve the voice quality and intelligibility of the paging system. In most cases, the 10 kHz and 80 Hz controls should be placed in minimum position while the 300 Hz, 1 kHz and 3 kHz should be moved toward maximum for improved presence. Each system, depending on the speakers used and room acoustics, will require some experimentation with the controls for optimum results.

11. Note and record the settings of the individual filter controls and the MASTER control. These settings are generally applicable to all four MIC input channels, if the microphone remains in the same position.

12. If the position of the microphone is changed or additional microphones are used, some adjustment in the feedback controls may be necessary.

COMPRESSOR LIMITER: The COMPRESSION control is used to provide relatively uniform output from the amplifier regardless of variations in the input levels. This is particularly important in speech applications, where a microphone may be used by a number of people with varying voices and microphone techniques. It is also useful for musical programs, particularly when handling background music.

The COMPRESSION control is turned clockwise to the higher numbers to reduce the output range for a given variation in input range. Turn the control counter-clockwise to lower numbers to increase the output range. To remove compression and restore the normal full range of the amplifier, turn the control fully counter-clockwise to zero.

To determine the optimum setting of the COMPRESSION control for speech applications, proceed as indicated below. For music, the setting will generally be lower than for speech.

Set the COMPRESSION control fully counter-clockwise to zero position. Set the MASTER volume control to the highest level likely to be required. Use a level setting that will permit you to pick up clearly spoken inputs in a low voice at a distance of three feet on axis from the microphone. However, do not set the volume level so high as to produce feedback or howling.

Then, speaking in a loud voice directly into the microphone, turn the COMPRESSION control clockwise to the point where the output of the amplifier is reduced to the same level as obtained above. The MASTER control can be used to vary the over-all volume without upsetting the COMPRESSION adjustments.

MIC VOLUME: The four individual MIC volume controls are used to adjust the level of each microphone input channel. The control is turned clockwise (to the higher numbers) to increase the volume and counterclockwise to reduce it.

AUX VOLUME: This control serves a two-fold purpose. It selects either of the two auxiliary inputs and it controls the volume of the selected auxiliary input. To select the AUX 1 input, rotate the control counterclockwise past the center position. Turning this control counter-clockwise to the higher numbers increases the AUX 1 volume. To select the AUX 2 input, rotate the control clockwise past the center position. Turn the control more clockwise to increase the AUX 2 volume.

If the auxiliary input is not to be used, set the control to the center position. The center position is indicated when the triangle on the control knob coincides with the vertical line between the AUX 1 and AUX 2 designations.

MASTER: This control is used to regulate the overall volume of the amplifier, which may include the mixed output of two or more input channels. To set this control, rotate it to *maximum clockwise position, then set the individual MIC and AUX controls to the highest level likely to be used and consistent with the operation of the limiter compressor. Adjust the MASTER control to the desired listening level for the mixed output.

POWER: This switch applies power to the amplifier. It will also turn on any associated equipment which may be connected to the auxiliary power receptacle on the rear panel. The POWER indicator lamp will go on to show that power has been applied to the unit.

ACCESSORIES

The installation of accessory transformers requires the removal of the cover, which presents an electrical shock hazard. For this reason, these accessories must be installed only by a qualified technician.

MIC INPUT TRANSFORMERS: Bogen TM200A and TM500A plug-in transformer accessories are designed to convert the input impedance of the amplifier to that of a low-impedance microphone. Model TM200A accommodates 200-ohm mics, and the TM500A 500/600-ohm microphones.

The **Acousta-Master** CT amplifiers are furnished ready for use with high-impedance microphones. To convert any of the microphone inputs to balanced low-impedance use, refer to figure 5 and proceed as follows:

1. Remove four screws on each side of cover and the cover (1).
2. Remove two knobs (2).
3. Remove two nuts (3).
4. Remove two screws (4).
5. Remove preamplifier board A1. Turn board over.
6. Install low impedance transformer(s) in 9-pin socket(s). XI is for MIC 1 input; X2 is for MIC 2 input.
7. Use spring clip(s) to secure transformer(s) in socket(s).

8. Change jumper connections as indicated in the table below.

9. At preamplifier board A2, install low impedance transformer(s) in 9-pin socket(s). XI is for MIC 4 input; X2 is for MIC 3 input.

10. Use spring clip(s) to secure transformer(s) in socket(s).

11. **Change jumper connection as indicated in the table below.**

Transformer Plugged in for:	Remove Jumper between:	Reconnect Jumper between:
MIC 1 Conversion	Pins 8 & 18	Pins 7 & 9
MIC 2 Conversion	Pins 11 & 19	Pins 10 & 12
MIC 3 Conversion	Pins 11 & 19	Pins 10 & 12
MIC 4 Conversion	Pins 8 & 18	Pins 7 & 9

12. Mount preamplifier board A1 on the amplifier, using two screws at the rear, two nuts over the control shafts, and the two control knobs. Replace cover.

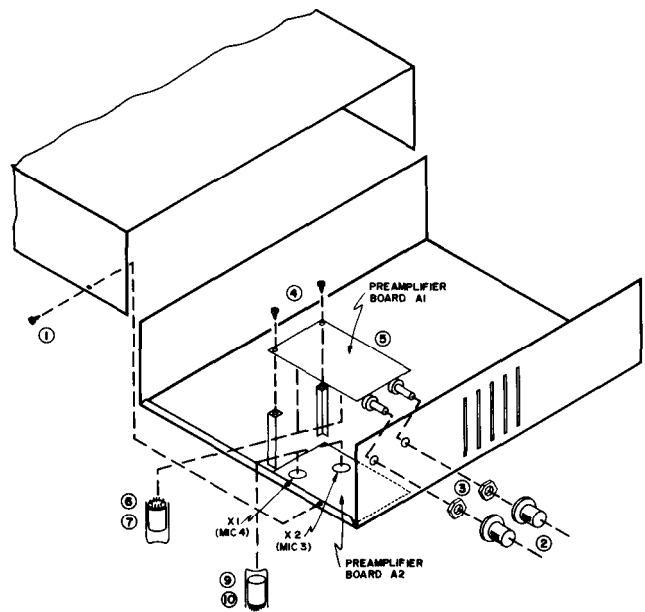

Figure 5 - Installing Low-Impedance MIC Input Transformers

LVP-1 AND RVC-2A UNITS: The Bogen LVP-1 is a plug-in accessory which provides microphone precedence over the MIC or AUX channel to which the accessory is connected. The LVP-1 may be used with the MIC 1, MIC 4 and AUX channel, and a separate accessory is required for each channel.

The LVP-1 unit is also used in conjunction with the Model RVC-2A accessory to provide remote volume control of these channels. The RVC-2A will control the output level at distances up to 2000 feet from the amplifier.

MIC PRECEDENCE: The MIC 1 and MIC 4 input channels as well as the AUX channel may be remotely controlled by installing the LVP-1 accessory. Plug the accessory into the appropriate LVP-1 accessory socket on the Preamplifier Board Assembly, after removing the amplifier cover as previously described. The MIC 1 socket is on the top preamp board (A1), MIC 4 socket is on the bottom board (A2), and the AUX socket is on the main component board (A3).

Connections are made from an external switch to the appropriate MIC 1, MIC 4 or AUX terminal and to GND terminal on the REMOTE CONTROL PRECEDENCE strip on the rear panel. The switch on the paging microphone may be used for this purpose, if it has a normally open pair of contacts for the precedence function, as on the Shure 450 microphone. Otherwise, an external single-pole, single-throw switch may be installed near the microphone. When the switch contacts are closed, the controlled channel is muted. For detailed information on MIC precedence connections, see the instruction sheet furnished with the LVP-1 accessory.

REMOTE VOLUME CONTROL: Plug an LVP-1 accessory into each channel to be remotely controlled, as described above. Connect the RVC-2A remote volume control to the REMOTE CONTROL PRECEDENCE terminal strip TSI01 on the rear panel of the amplifier. Connect one lead from the accessory to the appropriate MIC 1, MIC 4 or AUX terminal and the other lead to GND.

After connecting the RVC-2A, turn its control knob fully clockwise and the volume control for the appropriate amplifier channel counter-clockwise. Advance the volume control on the amplifier to the loudest position likely to be used or to the point where feedback begins. Reduce the output level at the RVC-2A control to the desired level, and adjust the control as necessary during operation.

MODEL WMT-1 TELEPHONE LINE TRANSFORMER:

The Bogen Model WMT-1 input/output matching transformer is an accessory which has been designed especially for matching either inputs from or outputs to a 500/600-ohm line. As an input matching transformer, it may be used with the Bogen amplifier for distributing background music or a page which has been transmitted over leased telephone lines. The accessory also functions as an output matching transformer in feeding special program material over a 500/600-ohm telephone line for transmission to a local broadcast studio.

MODEL LPC/4A PHONO PLAYER TOP: The Model LPC-4A is a three-speed, ac-operated phono player top designed for mounting on the amplifier. The phono player is furnished complete with all necessary mounting hardware, and only a screwdriver is required to install it on the amplifier. A tone arm housing a dual-stylus flip-over cartridge for standard or 78 rpm records is furnished with the unit.

MODEL RPK-33A RACK PANEL: The RPK-33A rack panel is designed to mount the CT amplifiers in a standard 19" sound rack. Instructions are furnished with the RPK-33A instruction sheet.

MODEL LK-12 LOCKING PLATE: Equipped with a lock and 2 keys. Fully conceals the control panel to prevent tampering with the controls of a Bogen amplifier.

MAINTENANCE

Some servicing procedures require removal of the cover or bottom plate, as described previously. There are no user-serviceable parts inside the amplifier enclosure. Have all interior servicing done by a qualified technician.

BOGEN SERVICE

We are interested in your Bogen amplifier for as long as you have it. If trouble ever develops with your unit, please do not hesitate to ask our advice or assistance. Information can be obtained by writing to Service Department, Bogen Division/Lear Siegler, Inc., P.O. Box 500, Paramus, New Jersey 07652.

When communicating with us, give the model number and series designation of your unit. Describe the difficulty encountered and the effects each operating control has upon the symptoms of trouble. Include details on electrical connections to associated equipment, and list such equipment. When we receive this information, we will send you service information if the trouble appears to be simple. If the trouble requires servicing, we shall send you the name and address of the nearest Bogen authorized service agency to which you can send your unit for repairs.

When shipping your unit, pack it well, using the original shipping carton or a similar container and filler material, to prevent damage in transit. Remove any plug-in transformers from the PC board before shipping. Send the unit fully insured and prepaid. The unit will be promptly repaired and returned to you express collect.

CIRCUIT BREAKER

The power line is protected by a circuit breaker, which shuts off the power and turns off the POWER indicator in case of overload. The breaker is reset by pressing in the red reset button located on the rear panel. If the amplifier shuts off again after resetting the breaker, make no further attempt to operate the equipment. Call a serviceman to locate the cause of the trouble.

THERMAL BREAKER

The output transistors are protected by a thermal overload device, which shuts off the unit when the temperature of the unit rises excessively. When the unit is shut off by the thermal overload device, the POWER indicator on the front panel remains on. Check the output transistors and replace defective transistors as indicated below.

REPLACING TRANSISTORS

When replacing the driver transistors, press a small screwdriver blade into the side of the U-clip heat sink to spread the jaws of the clip. Draw the clip and screwdriver off the metal tab on the driver transistor. Reverse the procedure to install the clip on the replacement transistor. Since the U-clip heat sink is a spring clip, avoid spreading the jaws too wide.

When replacing the output transistors, clean all foreign matter from the heat sink, insulator, and transistor. Brush a generous amount of silicon compound such as Dow Corning No. 340 to completely cover both surfaces of the insulator (Part No. 16-9278-01). Place the insulator between the heat sink and the replacement transistor. Use the original transistor mounting hardware to mount the replacement transistor.

The above procedure may require some dismantling of the heat sink. It is therefore important to also clean the contact surface of the thermal breaker and to apply the silicon compound to the thermal breaker before reassembling the heat sink. Make certain the thermal breaker makes firm contact with the heat sink.

REPLACEMENT PARTS

Most components used in the amplifier are standard parts available through reputable parts suppliers. The parts listed here may be obtained from Bogen distributors, service agencies or directly from the factory. When ordering a part, specify a part number, the model of the unit, and give the series designation, which is a letter followed by numbers, printed on the chassis. For parts on circuit boards, also give the component board assembly number, which begins with "45".

When replacing transistors, use those made by the specified manufacturers. Transistors from other suppliers may not be satisfactory. Certain resistors must be Allen-Bradley products. These are designated by "AB" on the schematic diagram.

Ref. No.	Part No.	Description
A3	45-9813-01	PC board assembly
C3,19	79-008-049	Capacitor, electrolytic, 500 μ F, 35V
C5, 17,18	79-008-057	Capacitor, electrolytic, 50 μ F, 50V
C15	79-504-032	Capacitor, tantalum, 2.2 μ F, 15V
C25	79-1 12-001	Capacitor, electrolytic, 500 μ F, 75V
c29	79-008-058	Capacitor, electrolytic, 10 μ F, 50V
c31	79-008-062	Capacitor, Electrolytic, 1 00 μ F, 50V
CR1, 2,6	96-5333-01	Diode, 400 piv @ 1 A
CR3	96-5344-04	Diode, zener, 18V, 2W
CR4	96-5344-02	Diode, zener, 12V, 2W
CR5	96-5202-01	HVR 3
L1-3	95-5 162-01	Inductor, 150 μ H
L4	95-5 163-01	Inductor, 50 μ H
L5		Inductor, 1 5 μ H
Q1-4,6-8	95-5164-01 96-5213-01	Transistor, 2N5089 or
Q5	96-5346-01	Transistor, BC 239C
Q9	96-5 96-5298-01 176-01	Transistor, MPS-65 18 Transistor, SPS-1910
Q10	96-5283-01	Transistor, MPS-A55
Q11	96-5357-01	Transistor, 2SD-389 (P) /2SD313D/TIP31A
Q12	96-5356-01	Transistor, 2SB-5 12 (P) /2SB507D/TIP32A
R1	77-001-712	Control, aux vol., 2 megohm C.T.
R23	77-00 1-709	Control, comp., 50 kilohm
R32	77-001-722	Control, master vol., 10 kilohm
R48	75-842-561	Resistor, 560 ohm, 3W
R65, 69	76-107-096	Resistor, .82 ohm, 2W
R67, 68	76-116-003	Resistor, .27 ohm, 7W

Schem. Ref.	Part No.	Description
Chassis electrical components		
C106	79-509-05 1	Cap, electrolytic, 1500 μ F, 75V (CT-35)
	79-509-052	Cap, electrolytic, 2000 μ F, 75v (CT-60)
	79-509-053	Cap, electrolytic, 3000 μ F, 75V (CT-100)
C107	79-509-O 15	Cap, electrolytic, 750 μ F, 50V (CT-35)
	79-509-O 17	Cap, electrolytic, 1500 μ F, 50v (CT-60)
	79-509-O 19	Cap, electrolytic, 2500 μ F, 50V (CT-100)
CBIO1	94-00 17-04	Circuit breaker, .93A hold (CT-35)
	94-00 17-09	Circuit breaker, 1.65A hold (CT-60)
	94-00 17-15	Circuit breaker, 2.5A hold (CT-1 00)
CB-102	94-00 14-07	Thermal breaker, 105°C
CR-101, 102	96-5241-01	Diode, 300 piv @ 3A
CR-103, 104	96-5333-01	Diode, 400 piv @ 1A
1101	94-0302-05	Pilot lamp assembly
QIO1-106	96-5385-01	Transistor, 2N3055H RCA (CT-35,60)
	96-5397-01	Transistor, 2N3055 Solitron (CT-1 00)
RIO1-105	77-001-723	Control, slide, 500 kilohm
R108	75-741-101	Resistor, 100 ohm, 7W
R109, 110	76-116-003	Resistor, .27 ohm, 7W (CT-1 00)
SW101	81-003-057	Switch, ac, 3A (CT-35,60)
	81-003-053	Switch, ac, 6A (CT-100)
TIO1	83-805-000	Transformer, power (CT-35)
	83-804-000	Transformer, power (CT-60)
	83-803-000	Transformer, power (CT-100)
T102	83-422-000	Transformer, output (CT-35)
	83-423-000	Transformer, output (CT-60)
	83-424-000	Transformer, output (CT-100)

Pre-amp board components

A1, A2	45-7082-01	PC board assembly
C4,13	79-008-05 1	Cap, electrolytic, 25 μ F 35V
Q1,2	96-5213-01	Transistor, 2N5089 or
	96-5346-01	Transistor, BC 239C
R1, 2, 15, 16	76-147-126	Resistor, 4.7 ohm, 1/2W
R14,25	77-001-711	Control, 1 megohm

Mechanical components

03-0628-02	Control, anti-feedback
03-0593-01	Control, aux 1, 2 vol.
03-0641-01	Control, mic 1, 2 vol.
03-0592-01	Control, master vol., comp., mic 3,4

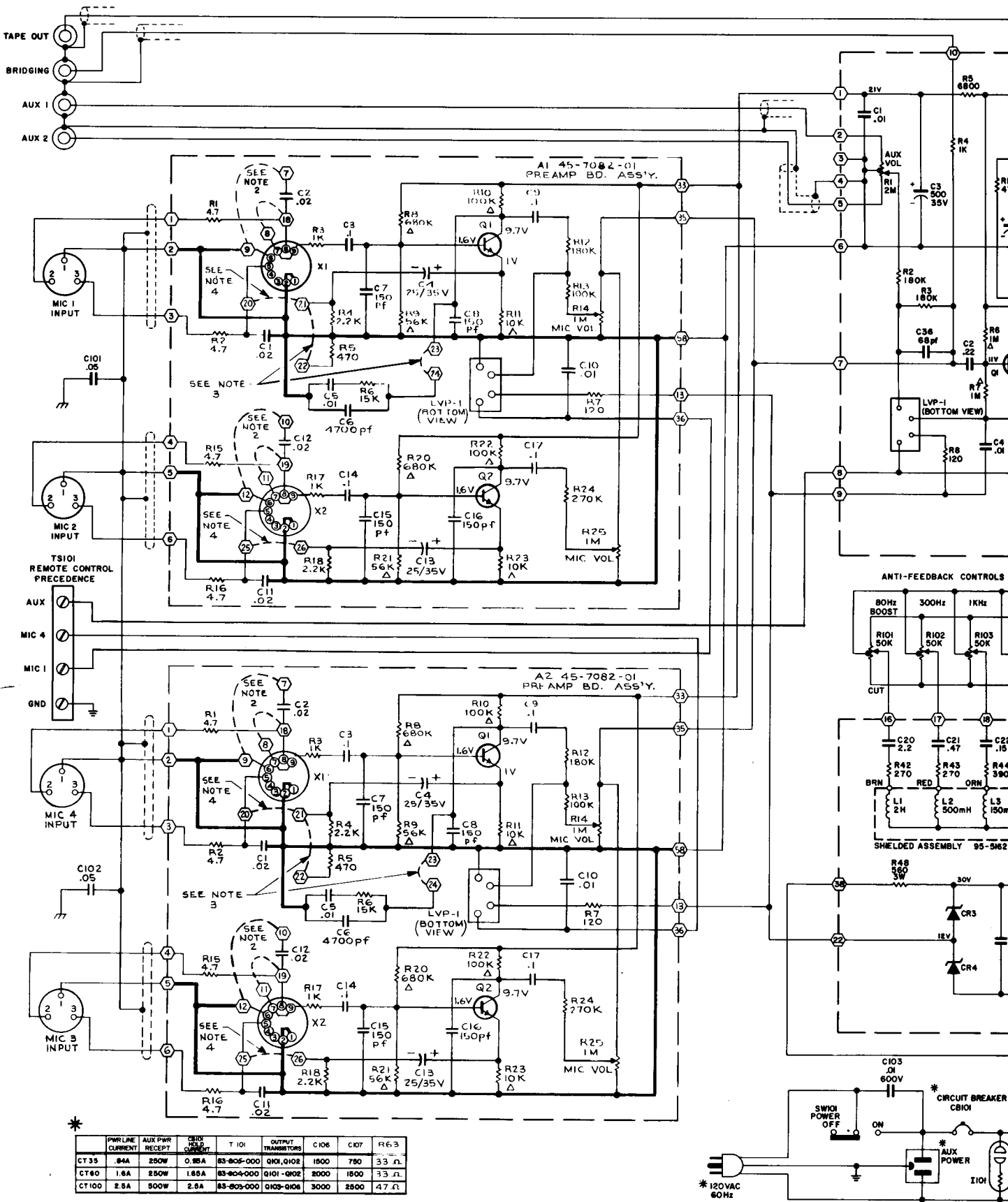

	PWR LINE CURRENT	AUX PWR RECEPT	CHD 250 P CURRENT	T 101	OUTPUT TRANSFORMERS	C106	C107	R63
CT 35	.84A	250W	0.95A	83-805-000	Q101, Q102	1500	780	33 Ω
CT 60	1.8A	250W	1.85A	83-804-000	Q101-Q102	2000	1500	33 Ω
CT 100	2.8A	500W	2.8A	83-803-000	Q103-Q108	3000	2500	47 Ω

Figure 6—Schematic diagram

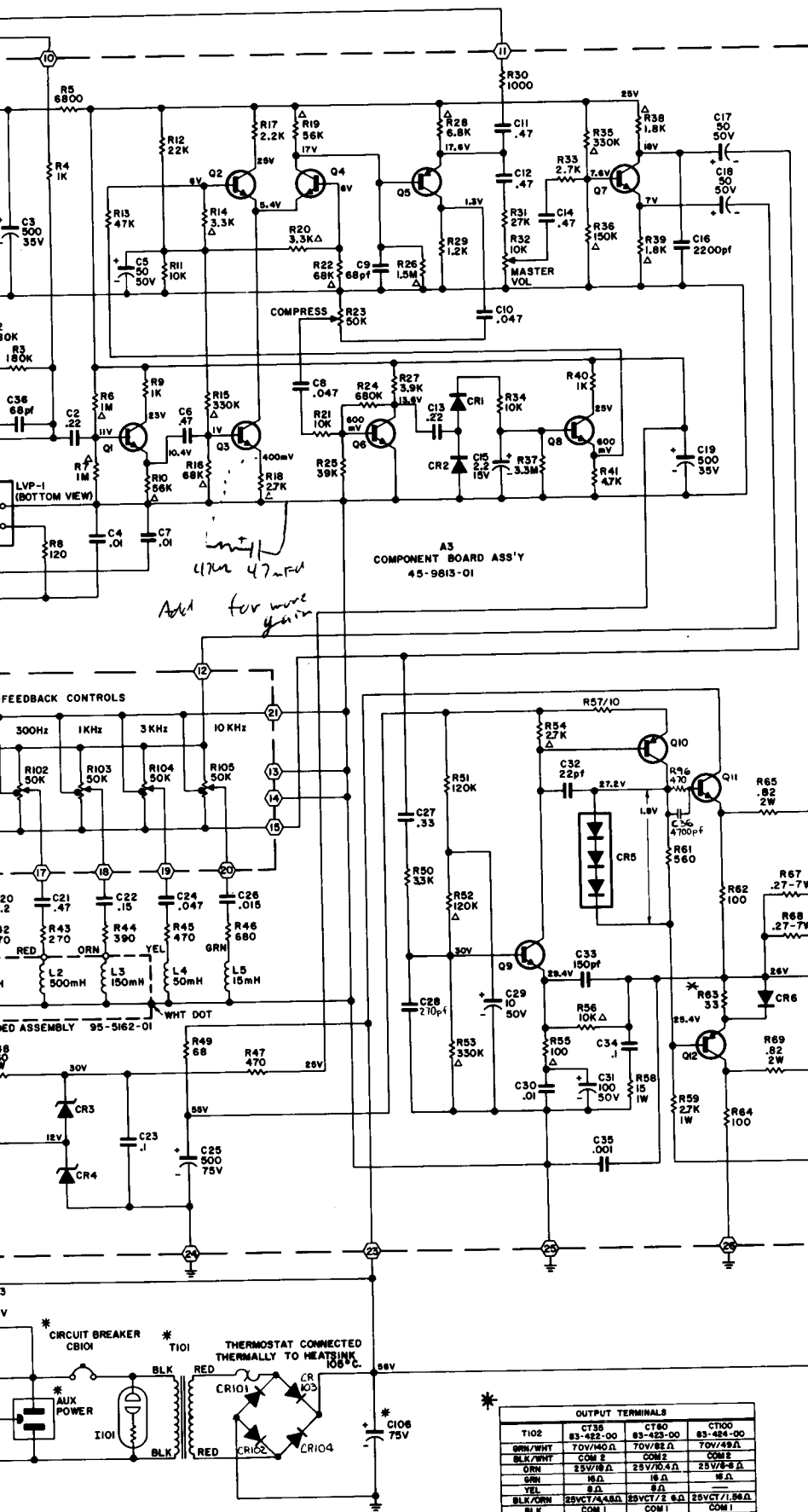

NOTES :

1. UNLESS OTHERWISE SPECIFIED ALL RESISTORS ARE 1/2 WATT $\pm 10\%$; CAPACITORS ARE IN MFD.
2. FOR BALANCED LOW-IMPEDANCE MIC INPUT'S PLUG IN TM TRANSFORMERS IN APPROPRIATE X1 OR X2 SOCKETS. AT X1, REMOVE JUMPER BETWEEN PINS 8 AND 18, AND CONNECT JUMPER BETWEEN 7 AND 9. AT X2, REMOVE JUMPER BETWEEN PINS 11 AND 19, AND CONNECT JUMPER BETWEEN PINS 10 AND 12.
3. TO CONVERT CHANNEL FOR A MAG PHONO INPUT, CONNECT JUMPER BETWEEN PINS 21 AND 22; 23 AND 24.
4. FOR LOW-Z UNBALANCED INPUT, CONNECT JUMPER BETWEEN PINS 20 AND 21 AT X1, OR 25 AND 26 AT X2. CONNECT JUMPER BETWEEN 1 AND 2 OF YOUR MIC PLUG. CONNECT THE CONDUCTOR LEAD OF YOUR MICROPHONE TO PIN 3.
5. (Δ) INDICATES ALLEN BRADLEY RESISTORS USED FOR LOW NOISE.

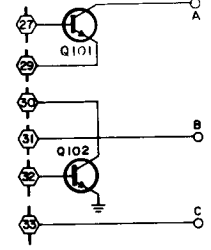

CT 35 + 60 OUTPUT WIRING

TRANSISTOR CONFIGURATION

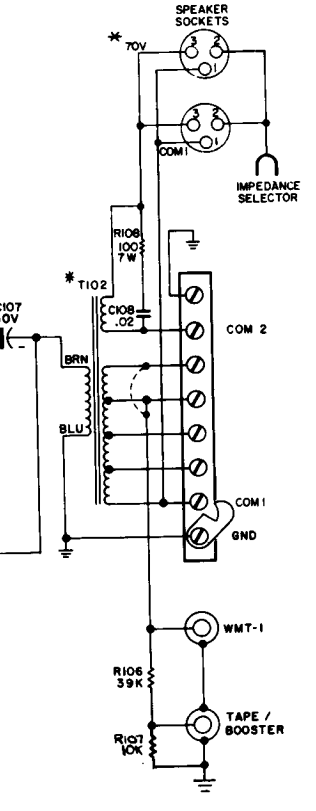
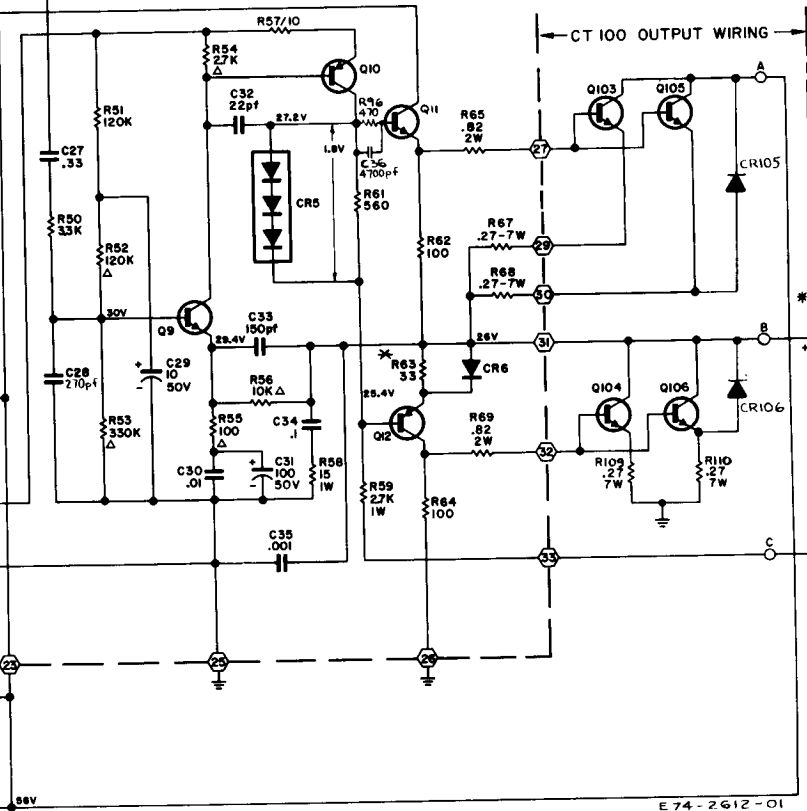
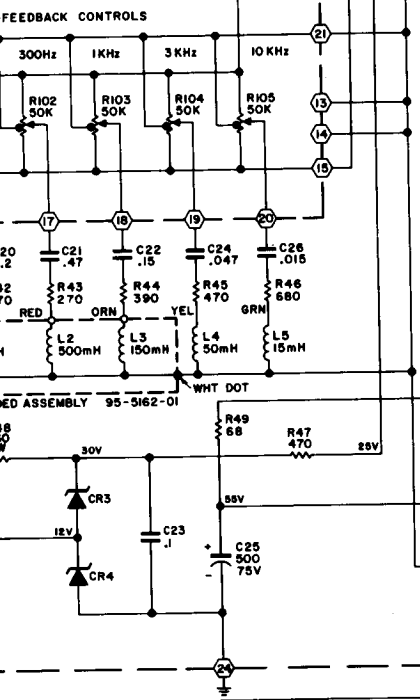
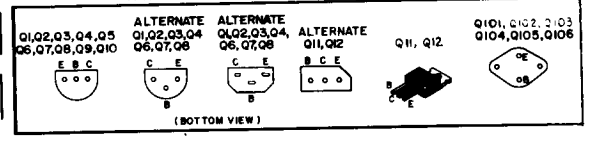

OUTPUT TERMINALS			
T102	CT35	CT60	CT100
BRN/WHT	83-422-00	83-425-00	83-424-00
BLK/WHT	70V/160 Ω	70V/82 Ω	70V/49 Ω
GRN	COM 2	COM 2	COM 2
GRN	25V/16 Ω	25V/10.4 Ω	25V/6.8 Ω
GRN	16 Ω	16 Ω	16 Ω
YEL	8 Ω	8 Ω	8 Ω
BLK/GRN	25VCT/1.6A Ω	25VCT/2.5 Ω	25VCT/1.6A Ω
BLK	COM 1	COM 1	COM 1
BLK/YEL	-	-	4 Ω