



**PUBLIC ADDRESS  
AMPLIFIERS**

**Models C10B & C20B**

**DESCRIPTION**

The Bogen Models C10B and C20B solid-state public address amplifiers are rated at 10 watts and 20 watts, respectively, and are UL and CSA listed.

The units will accommodate most microphone types, offering the capability for both high impedance and low impedance microphones. A front panel selector switch allows one of the two microphone channels (MIC 2) to be used as an auxiliary input, which can be muted when a customer-supplied SPST normally-open switch is used for microphone precedence.

Independent volume controls and a treble control, for adjustment of tonal balance, are provided.

Balanced or unbalanced outputs are provided for 4, 8, and 16 ohm speakers, and 25 volt constant-voltage systems. A terminal strip with screw terminals allows convenient connection of speakers, except 70 volt. For 70 volt operation, a quick-disconnect speaker socket is provided.

The C10B and C20B amplifiers operate from a 120 volt, 60 Hz source and have a maximum power consumption of 46 and 60 watts, respectively. A thermostat, enclosed in the power transformer, protects the unit against overloads.

**INSTALLATION**

**UNPACKING**

The amplifier was carefully checked before leaving the factory. Inspect shipping container and unit carefully for indication of improper handling; if the unit has been damaged, make an immediate claim to distributor from whom it was purchased, or if the amplifier was shipped directly to you, notify the carrier without delay and place your claim.

**POWER AND GROUNDING**

The ac line cord has a three-prong plug which should be plugged into a three-wire grounded, 120 volt, 60 Hz outlet. Since it is important to ground the amplifier, where a three-wire outlet is not available, use an adapter (e.g., Leviton No. 5017) and connect the grounding pigtail to the screw securing the wall plate. If the wall plate screw is not grounded, connect a wire from the GND terminal of the amplifier to a water or steam pipe.

**TECHNICAL SPECIFICATIONS**

	C10B	C20B
<b>POWER OUTPUT:</b>	10 watts	20 watts
<b>FREQUENCY RESPONSE:</b>	80 to 10,000 Hz $\pm$ 2dB	
<b>HUM AND NOISE:</b> (20 — 20kHz)	MIC Input 55dB below rated output AUX Input 70dB below rated output	
<b>SENSITIVITY:</b>	MIC HI-Z Input 3mV MIC LO-Z Input 300 $\mu$ V AUX Input 250mV	
<b>OUTPUTS:</b>	4, 8, 16 ohms 25V (62.5 ohms) 70V (500 ohms)	4, 8, 16 ohms 25V (31.3 ohms) 70V (250 ohms)
<b>OUTPUT CONNECTIONS:</b>	Screw-type terminals for 4, 8, 16 ohm and 25V tap Quick-disconnect socket for 70V tap	
<b>INPUT CONNECTIONS:</b>	2 MIC HI-Z jacks/2 MIC LO-Z terminals, AUX HI-Z jack, 500/600 line with WMT-1 accessory*	
<b>CONTROLS:</b>	MIC 1, MIC 2/AUX, Treble control	
<b>TONE CONTROL ACTION:</b>	Treble: 10kHz -11dB	
<b>POWER REQUIREMENTS:</b>	120 VAC 60Hz 46 watts	120 VAC 60Hz 60 watts
<b>SEMICONDUCTORS:</b>	All Silicon — 11 Transistors, 5 Diodes	
<b>DIMENSIONS:</b>	11 $\frac{3}{8}$ "W x 2 $\frac{7}{8}$ "H x 7 $\frac{3}{4}$ "D (28.9 x 7.3 x 19.7 cm)	
<b>WEIGHT:</b>	5 lbs. (2.27 kg)	6 lbs. (2.7 kg)

\*MIC 2/AUX are switch-selectable.

## AUXILIARY POWER

The auxiliary power receptacle on the rear chassis is a three-wire grounded outlet, which can supply power to accessory or associated equipment in the sound system. Be sure that the auxiliary component does not draw more than 300 watts. The power switch on the front panel of the amplifier does not control this receptacle. Equipment connected to this receptacle will remain on at all times unless turned off with its own On/Off switch.

Associated equipment connected to the auxiliary receptacle with a three-prong line cord will be grounded, providing the amplifier line cord has been properly grounded, as previously described. Otherwise, it may be necessary to ground the auxiliary equipment.

## INPUT CONNECTIONS

**MICROPHONE:** Connect low impedance microphones to the input screw terminals on the rear panel. High impedance microphones should be connected to the input jacks provided.

**MICROPHONE PRECEDENCE:** A built-in circuit provides muting over the MIC 2/AUX channel. This is achieved by connecting a customer-supplied SPST normally-open switched microphone cable to the MIC 2/AUX MUTE screw terminals.

**AUX:** To connect a turntable (with ceramic cartridge) to the AUX jack, use a single-conductor shielded cable terminated in a standard RCA phono plug. It is recommended that a separate ground wire be connected between the turntable base and the amplifier GND terminal to minimize hum pick-up.

The AUX input may also be used for any other signal source having a high level (.15V) output, such as the Bogen Model TP50 FM/AM Tuner.

### Connecting Low-Impedance Unbalanced Microphone Inputs

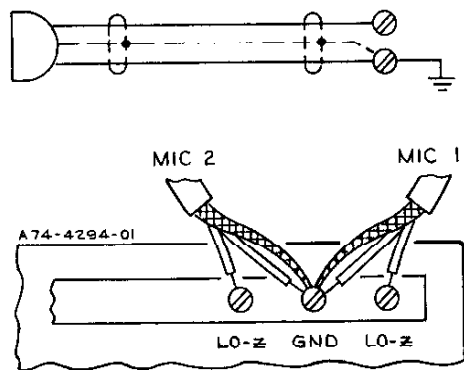

### Connecting High-Impedance Microphone Inputs

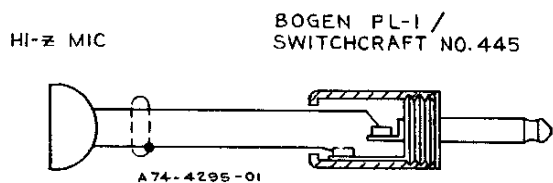

Figure 1 — Connecting Microphone Cables

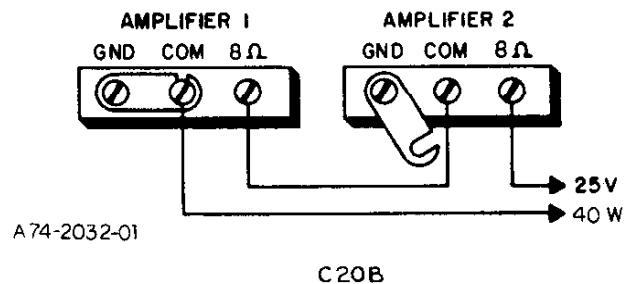
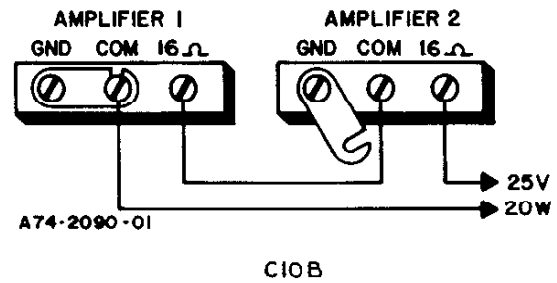

Figure 2 — Connecting Amplifiers in Series

## OUTPUT CONNECTIONS

**SPEAKERS:** The amplifier may be used with speaker systems rated at 4, 8 and 16 ohms and with 25-volt and 70-volt constant voltage systems. For detailed information on the installation of multiple speaker systems, refer to the Speaker Installation Instructions (No. 54-5001).

Connect the speaker system directly to the speaker output terminals on the rear of the amplifier. Connect one speaker lead to the COM terminal and the other to the terminal corresponding to the impedance of the speaker system. For balanced output lines, remove the link between COM and GND output terminals. If the line is shielded, connect the shield to GND. The 70V output is available only through the 3-pin connectors.

### Caution

To minimize shock hazard, Class 1 wiring as defined in local building codes should be used for 70-volt outputs. All other outputs may use Class 2 wiring.

### CONNECTING AMPLIFIERS IN SERIES

Pairs of Bogen C10B or C20B amplifiers can be connected in series to effectively double the power output into the same speaker system. See figure 2 for connection diagram. Be certain to remove the link between COM and GND of amplifier No. 2. Note that this arrangement is for unbalanced speaker lines. For balanced lines also remove the link between COM and GND of amplifier No. 1.

The input cabling must be arranged to parallel the inputs of the two amplifiers, and the volume and tone controls of both amplifiers must be at the same setting to assure that each amplifier will share the load equally.

## OPERATION

**POWER:** The front panel on-off switch applies power to the amplifier. It has no effect upon equipment connected to the auxiliary receptacle on the rear panel. The switch illuminates to indicate that power is on.

**MIC 1, 2:** The MIC 2/AUX selector switch should be in the MIC 2 mode. The MIC controls are used to adjust the volume of the microphone inputs. Rotate the control clockwise to increase volume or counterclockwise to decrease volume. When microphone is not in use, be certain to turn control to minimum position.

**AUX:** Set the MIC 2/AUX selector switch to AUX. The AUX control is used to adjust the volume of the auxiliary input. Rotate the control clockwise to increase volume and counterclockwise to decrease volume. Rotate the control to the minimum position when auxiliary input is not used.

**MICROPHONE PRECEDENCE:** A built-in circuit provides muting of the AUX channel. Connections are made from an external switch to the AUX MUTE terminals. An SPST normally-open switch is required for this function. When contacts are closed, the AUX channel is muted.

**TREBLE:** Use the TREBLE control to adjust the tonal balance of the amplifier output.

## ACCESSORIES

**WMT-1 LINE-MATCHING TRANSFORMER:** The Bogen WMT-1 Line-Matching Transformer provides an impedance match between the amplifier and a 0 level, 500/600 ohm line. This may be a telephone line connected to the switchboard for internal paging or used with a wired music system. No soldering is required to connect the WMT-1 to the amplifier.

To connect the input from a balanced 500/600 ohm telephone line, mount the WMT-1 on the rear panel of the amplifier, using the holes indicated on the rear panel. Connect the input line to the three-screw terminal board on the WMT-1. Connect the phono plug on the WMT-1 cable to the AUX jack on the rear of the amplifier. If this jack is being used for other auxiliary equipment, the WMT-1 may be connected to the MIC input. In order to do this, the WMT-1 wiring must be modified as described in the instruction sheet supplied with the WMT-1.

**WMK-1 IN-WALL MOUNTING KIT:** The Bogen Model WMK-1 In-Wall Mounting Kit is designed to mount the amplifier flush in a wall. Depth of the mounted unit is 3½ inches.

**MODEL RPK-35B RACK PANEL KIT:** The RPK-35B rack panel is designed to mount the C10B or C20B amplifier in a standard 19" sound rack.

Before fitting the panel to the amplifier, remove the rubber feet from the bottom of the amplifier. Slide the amplifier into the rack panel from the rear. Using the screws from the feet of the unit, secure upward through holes in the panel and the bottom of the amplifier, where the feet had been mounted.

Overall dimensions of the RPK-35B are 3-1/2" H x 19" W with side panels 6-13/32" D (8.9 x 48.3 x 16.3 cm). Cutout dimensions are 2-5/8" x 11-7/16" (6.6 x 29 cm). The panel is fabricated from cold-rolled steel and has a black finish.

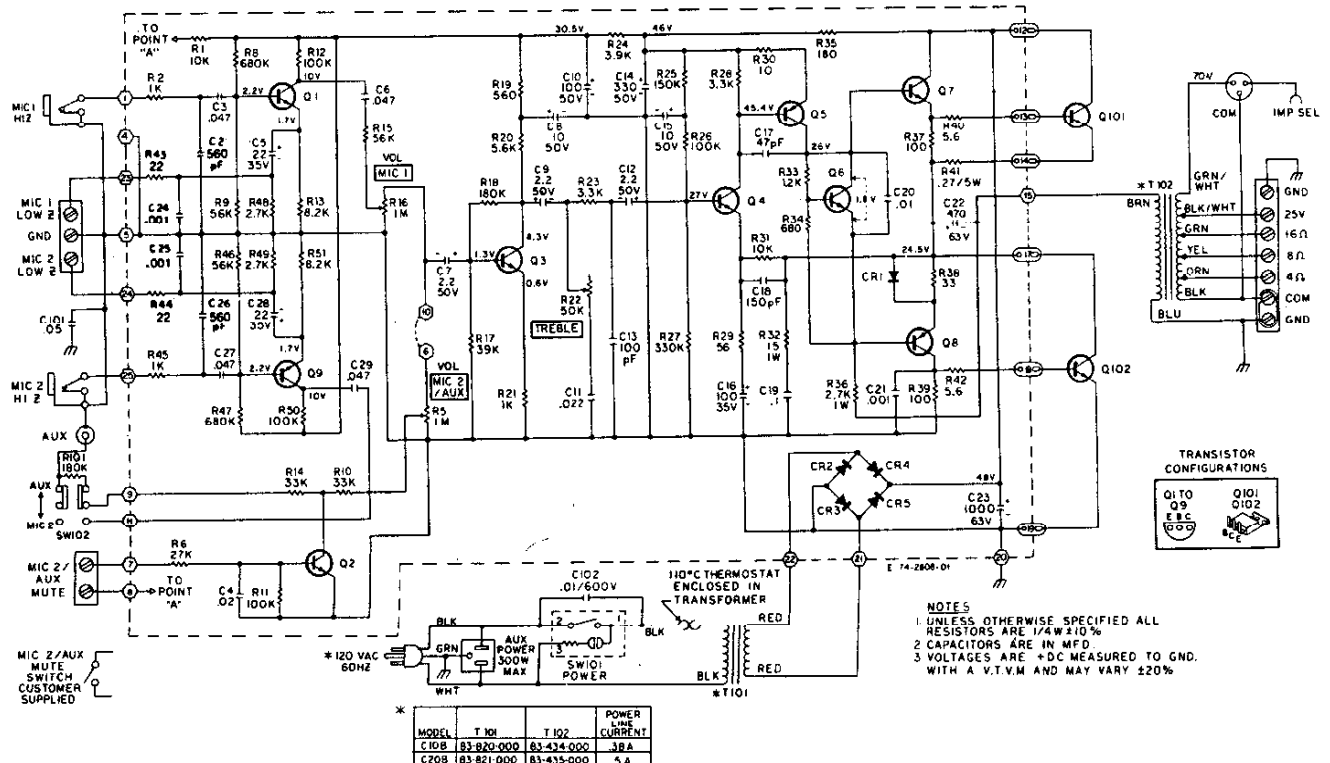

Figure 3 — Schematic Diagram, Models C10B & C20B