

AMPEX

MODEL 385

**OPERATION AND
MAINTENANCE MANUAL**

INSTRUCTION MANUAL
FOR
AMPEX MODEL 385 THREE CHANNEL MIXER

The Ampex Model 385 Three Channel Mixer has been designed to mix three low impedance microphone input sources to feed the input of the Bridging Meter Control Panel on the Ampex Model 300 Magnetic Tape Recorder. Sufficient amplification is provided before mixing to insure the highest possible signal-to-noise ratio and to allow the use of unterminated inputs.

SPECIFICATIONS

Inputs: Three microphone level inputs incorporating high level mixing. Shipped for 200 to 250 ohm impedance non-terminating. Can be strapped for 50 ohm, 125 to 150 ohm, and 500 to 600 ohm.

Output: Cathode follower output (unbalanced) designed to feed only the Bridging Input Meter Panels of the Model 300 Magnetic Tape Recorder.

Gain: Sufficient to produce the recommended operating level on the tape with an input signal of -94 dbm. on any channel. (Mixer level controls and Meter Panel Level control set for zero db attenuation.)

Frequency Response: \pm 1 db 30 to 15,000 cycles.

Noise: 65 db below signal for inputs of -50 dbm. This represents a noise equivalent to an input signal of -115 dbm.

Distortion: With a -50 dbm input signal and sufficient gain to modulate the tape 15 db above the recommended operating level, distortion is .2% RMS total harmonic on a 400 cycle tone.

Controls: Three 20 step attenuators (2 db per step tapered to infinity) are used as high level mixing controls. The record level control on the Meter Control Panel of the recorder functions as the master gain control. An External Line Key provides for switching the tape recorder to an external line.

Tubes: 5 6J7 Vacuum Tubes
1 6C5 Vacuum Tube

Power Requirements: 1.8 amperes at 6.3 volts, ac, and 10 milliamperes at 390 volts, dc, obtained from Electronic Assembly of the Model 300 Magnetic Tape Recorder.

Dimensions: For rack mounting - standard 19" wide panel - commercial notching - 7 inches high. Can be mounted in portable case of the Ampex Model 300 Tape Recorder.

Weight: 18 pounds.

INSTALLATION WITH MODEL 300 RECORDERS

I. POWER

Connect the Power Cable from the Power Supply Connector, J1905P, to the Remote Power Connector on the Electronic Chassis of the Model 300 Tape Recorder. The Meter Control Panel Power Cable should be inserted in the Meter Panel Connector, J1904S, on the Mixer.

II. OUTPUT

Connect the Mixer Output Cable from terminals 1, 2 and 3 on Mixer Terminal Strip, TS-1901, to terminals 1, 2 and 3 respectively on the Bridging Meter Control Panel. The cable shield connects to terminal 3 (ground). The external line connections are 4, 5 and 6 on Terminal Strip 1901 and become the input to the tape recorder when the Line Key is thrown. Terminal 4 should be strapped to Terminal 6 (Ground) for unbalanced operation.

III. INPUTS

The three microphone inputs are normally strapped for 200 to 250 ohm source impedance. For other impedances see Note 1 on the schematic diagram. Pins 1 and 2 on the Input Connectors are the microphone line in. The microphone cable shield should be connected to pin 3 (ground). Certain types of microphones may require resistive loading. In such cases, the recommended termination should be wired across the Input Connectors and the transformers strapped for the proper impedance.

IV. HEATER BALANCE ADJUSTMENT

The Heater Balance Potentiometer, R1927, is provided for balancing 60 cycle hum. It is adjusted at the factory and normally will not require readjustment. Some tubes require delicate balance of this potentiometer and even in balance may produce excessive hum. These tubes should be discarded.

NOTE: This mixer is subject to RF pickup in strong fields and should not be used in close proximity to broadcast transmitters.

REPLACEMENT PARTS LIST
MODEL 385 THREE CHANNEL MIXER

| Schematic Ref. No. | Description | Ampex Catalog No. |
|-----------------------|---|----------------------|
| A-1901 | 6-8 V. Panel Lamp - Bayonet Base | LA-5 |
| | Pilot Lamp Base | DL-3 |
| C-1901 | 50 MFD, 25 V. Electrolytic Condenser | CO-60 |
| C-1902 | 50 MFD, 25 V. Electrolytic Condenser | CO-60 |
| C-1903 | 50 MFD, 25 V. Electrolytic Condenser | CO-60 |
| C-1904 | 4 MFD, 450 V. Electrolytic Condenser | CO-54 |
| C-1905 | 4 MFD, 450 V. Electrolytic Condenser | CO-54 |
| C-1906 | 4 MFD, 450 V. Electrolytic Condenser | CO-54 |
| C-1907 | .1 MFD, 400 V. Oil Condenser | CO-40 |
| C-1908 | .1 MFD, 400 V. Oil Condenser | CO-40 |
| C-1909 | .1 MFD, 400 V. Oil Condenser | CO-40 |
| C-1910 | .25 MFD, 400 V. Oil Condenser | CO-41 |
| C-1911 | 50 MFD, 25 V. Electrolytic Condenser | CO-60 |
| C-1912 | 4 MFD, 450 V. Electrolytic Condenser | CO-54 |
| C-1913 | .1 MFD, 400 V. Oil Condenser | CO-40 |
| C-1914 | 50 MFD, 25 V. Electrolytic Condenser | CO-60 |
| C-1915 | .1 MFD, 400 V. Oil Condenser | CO-40 |
| C-1916 | 2 MFD, 600 V. Oil Condenser | CO-49 |
| C-1917 | 4 x 20 MFD, 450 V. Electrolytic Condenser | CO-65 |
| J-1901S | Microphone Connector Cannon P-3-13 | PL-111S |
| J-1902S | Microphone Connector Cannon P-3-13 | PL-111S |
| J-1903S | Microphone Connector Cannon P-3-13 | PL-111S |
| J-1904S | Power Connector Jones S-308AB | PL-54S |
| J-1905P | Power Connector Jones P-308AB | PL-8P |
| R-1901 | 2700 OHMS, 1 Watt Composition Resistor | RE-8 |
| R-1902 | 2700 OHMS, 1 Watt Composition Resistor | RE-8 |
| R-1903 | 2700 OHMS, 1 Watt Composition Resistor | RE-8 |
| R-1904 | 1 Megohm, 1 Watt Composition Resistor | RE-32 |
| R-1905 | 1 Megohm, 1 Watt Composition Resistor | RE-32 |
| R-1906 | 1 Megohm, 1 Watt Composition Resistor | RE-32 |
| R-1907 | 300,000 OHMS, 1/2 Watt Wirewound Resistor 1% | RE-52 |
| R-1908 | 300,000 OHMS, 1/2 Watt Wirewound Resistor 1% | RE-52 |
| R-1909 | 300,000 OHMS, 1/2 Watt Wirewound Resistor 1% | RE-52 |
| R-1910 | 250,000 OHMS, 20 Step Potentiometer | RE-237 |
| R-1911 | 250,000 OHMS, 20 Step Potentiometer | RE-237 |
| R-1912 | 250,000 OHMS, 20 Step Potentiometer | RE-237 |

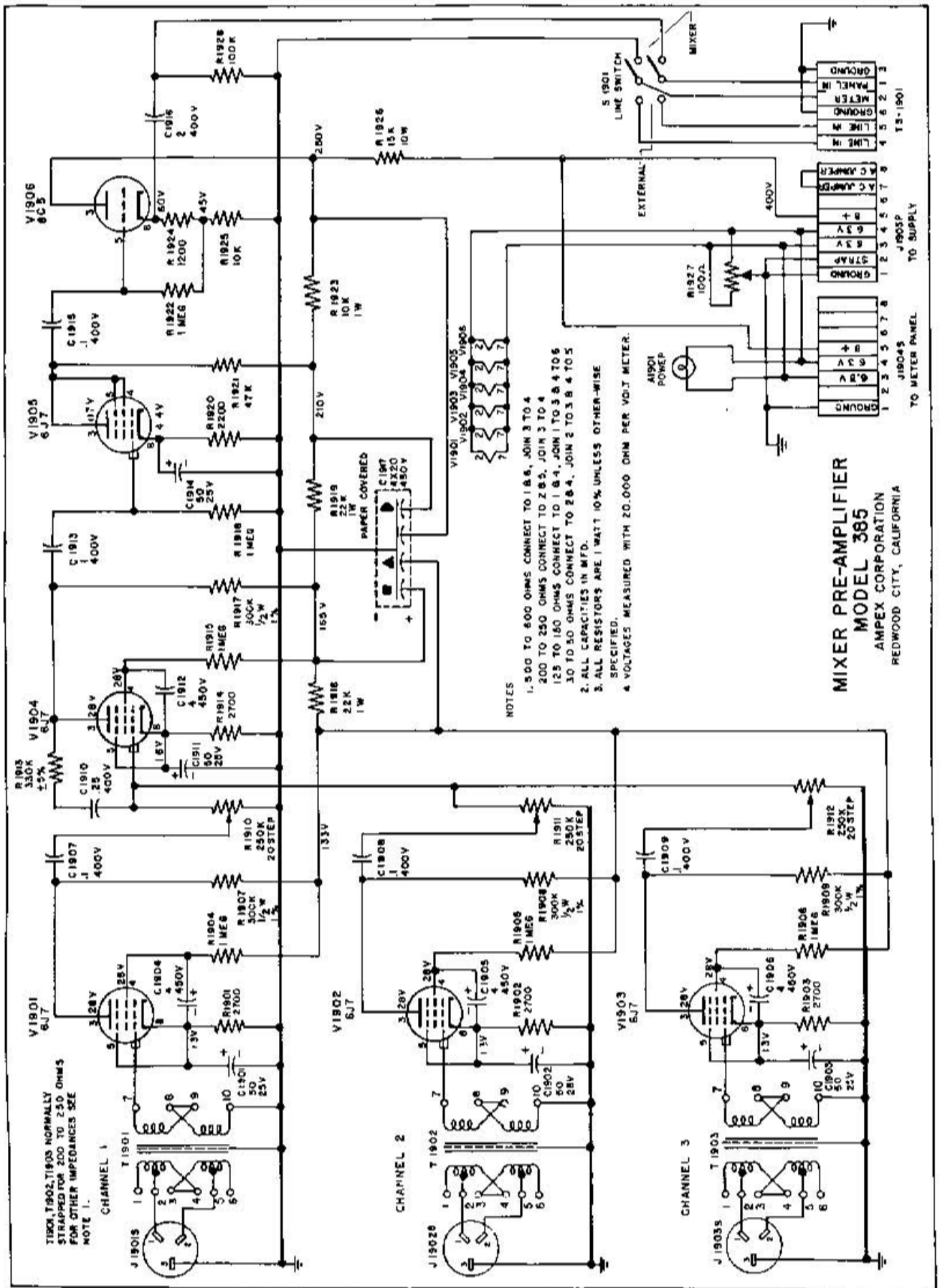

**MIXER PRE-AMPLIFIER
MODEL 385**
AMPEX CORPORATION
REDWOOD CITY, CALIFORNIA