

# No. 106-A AMPLIFIER

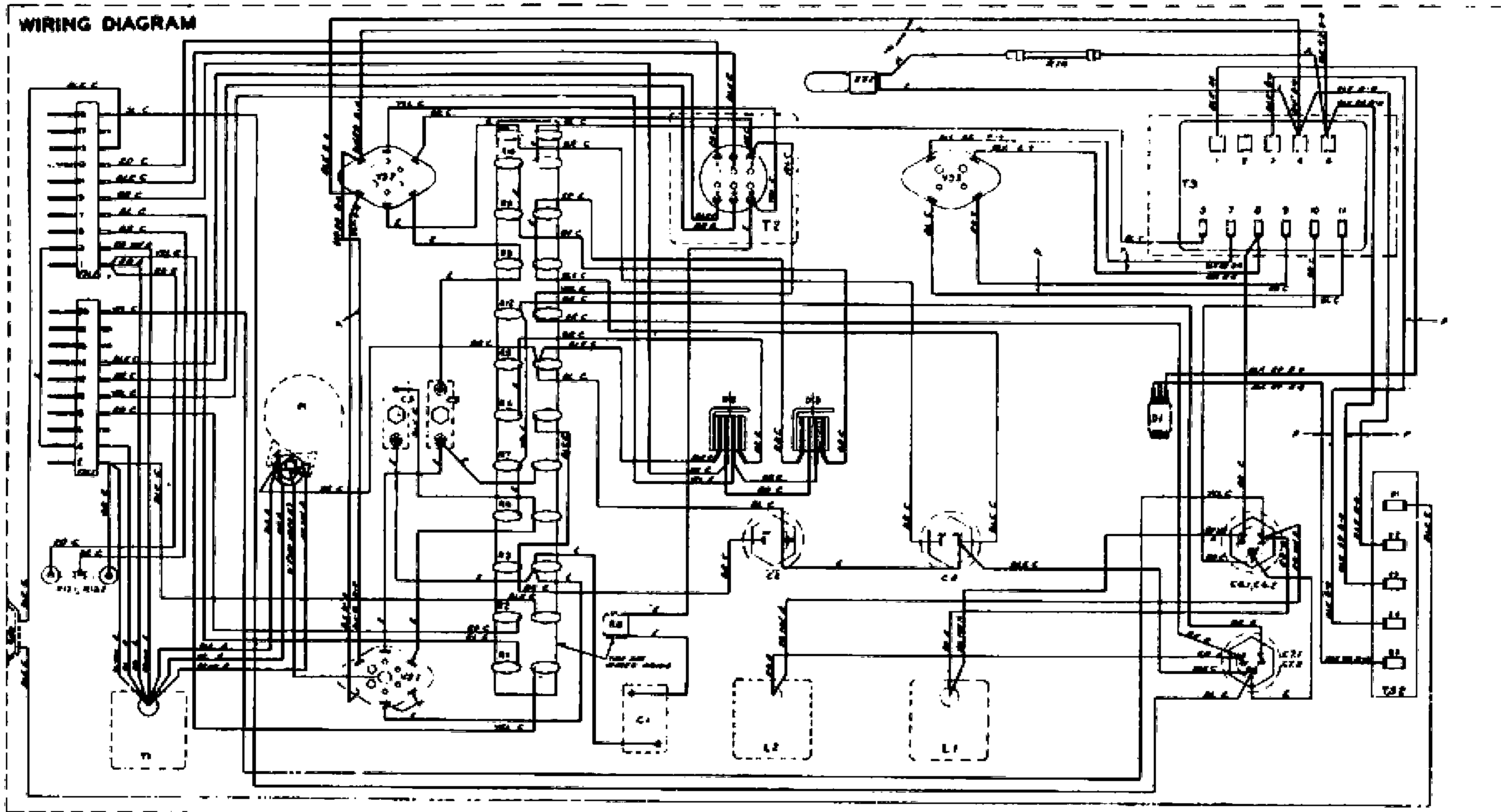

- NOTES:
1. WIRES MARKED "A" ARE FURNISHED AS PART OF APPARATUS AND SHALL BE SECURELY LACED TOGETHER AFTER APPARATUS IS WIRED.
  2. WIRES MARKED "B" ARE NO. 16 AWG SOLID WIRE PER KS-7612.
  3. WIRES MARKED "C" ARE NO. 22 AWG SOLID WIRE PER KS-7612.
  4. WIRE MARKED "D" IS ITEM 13B - ESR-611449.
  5. WIRES MARKED "F" ARE TWISTED PAIRS.
  6. APPARATUS DESIGNATIONS ARE FOR REFERENCE ONLY AND DO NOT APPEAR ON APPARATUS.
  7. WIRES MARKED "E" ARE STRAP WIRES PER P-311746, AND ARE OPEN FORMED.
  8. WIRES MARKED "O" ARE OPEN FORMED WIRES.

## SCHEMATIC

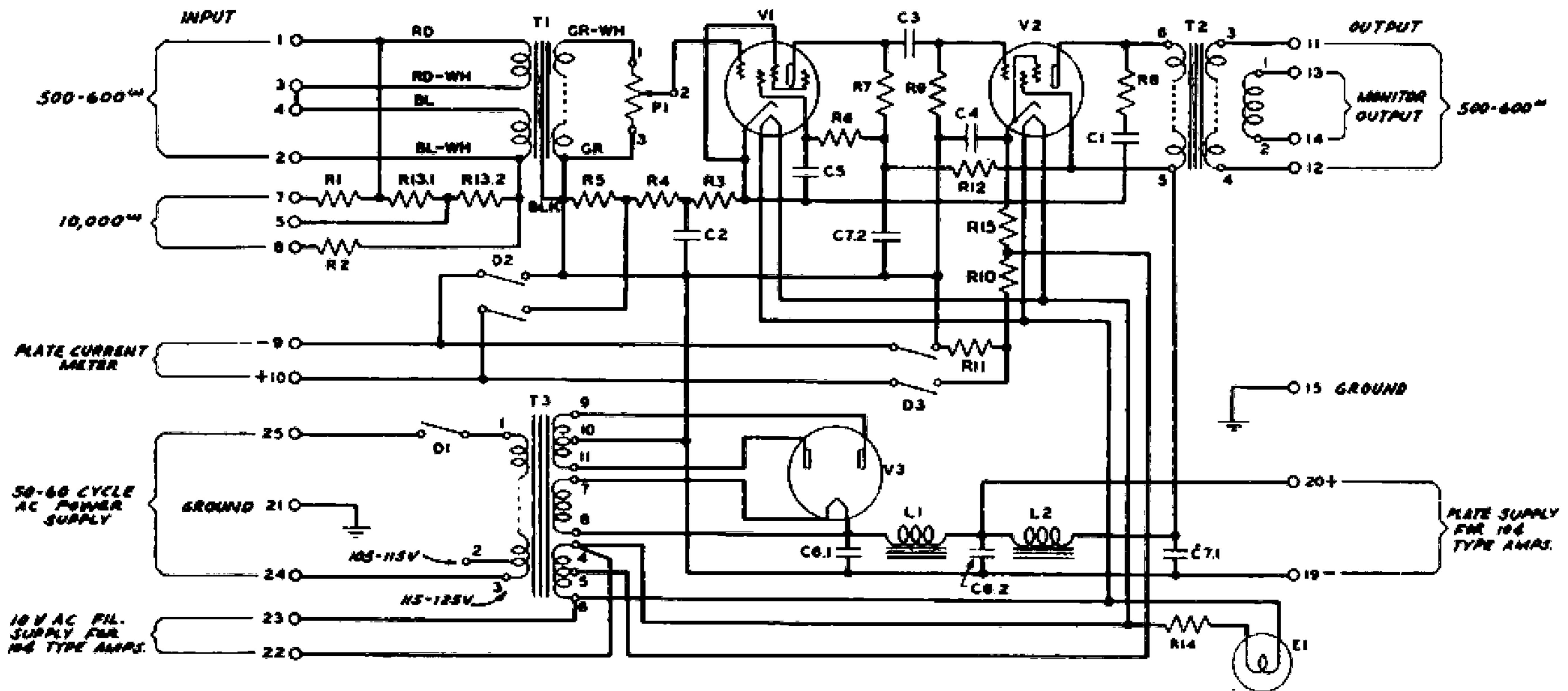

DESIGNATION	APPARATUS	DESIGNATION	APPARATUS	DESIGNATION	APPARATUS
T1	265E INPUT TRANSFORMER	I.R.C. TYPE BT-1 RESISTANCES (CONT'D)		P1	DAVEN CP-51 POT. 50,000 OHMS PER ESA-612056, "POT. NO. 2."
T2	165A OUTPUT TRANSFORMER	R6	1.0 MEGOHM ± 5%	D1	H.A.H. 20994-DQ SWITCH WITH 1/2" MTC. SLEEVE WITH 2 HEX. NUTS
T3	360C TRANSFORMER	R7,R9	0.25 MEGOHM ± 10%	D2,D3	TAYLEY MFG. CO. #2004 PUSH BUTTON SWITCHES
L1,L2	221H RETARDATION COILS	R12	30,000 OHMS ± 10%	E1	MAZDA #46 PILOT LAMP, 6.3 V.
C1	229C COND. 1.0 MF.	I.R.C. TYPE SW-1 RESISTANCES		ES1	AM. RADIO HARDW. CO. #36A LAMP SOCKET
C3,C5	230A COND. 0.4 MF.	R3	500 OHMS ± 2%	V3	EBY 33-11-C V.T. SOCKETS PER KS-7741
C2	CORNELL DUB. MA-13438-FE ELECTRO. COND. 100 MF. 12 V. DC. W.V.	R4	2000 OHMS ± 5%	V3S	EBY 33-11-A V.T. SOCKET PER KS-7741
C4	CORNELL DUB. MA-13368-FE ELECTRO. COND. 50 MF. 25 V. DC. W.V.	R5	111 OHMS ± 5%		
C6.1,C6.2	CORNELL DUB. MA-13257-FE ELECTRO. COND. 8-8 MF. 450 V. DC. W.V.	R10	300 OHMS ± 5%		
C7.1,C7.2	CORNELL DUB. MA-13257-FE ELECTRO. COND. 8-8 MF. 450 V. DC. W.V.	R11	5.0 OHMS ± 5%		
R13.1,R13.2	198U RESISTANCE, 606-606 OHMS	R15	160 OHMS ± 5%		
I.R.C. TYPE BT-1 RESISTANCES		R8	I.R.C. TYPE SW-3 RESISTANCE, 60,000 OHMS WITH TERN. LUGS		
R1,R2	5000 OHMS ± 10%	R14	ELEC/RAD TYPE "O" FLEXIBLE RESISTANCE, 15 OHMS, 6" OVERALL LENGTH		