

Product Data

- 4 inputs accept Lo-Z balanced or Hi-Z unbalanced signals
- RCA auxiliary input
- 2 Hi-Z balanced bridging inputs
- Mic over music muting available
- XLR, 1/4" phone and RCA output provided
- AC or DC powerable
- Optional rack-mounting available

Specifications:

Rated Output:

Aux: 4V (47k Ω unbal)

Hi-Z Mic: 125 mV (47k Ω unbal)

Lo-Z Mic: 10mV (150 Ω bal)

Frequency Response: 30 Hz – 20 kHz \pm 2 dB

Distortion: <1% @ rated output

Hum & Noise:

Lo-Z Mic: 122dB

Hi-Z Mic: 114dB

Bridge: 99dB

Aux: 76dB

Maximum Input:

Lo-Z Mic: 20mV

Hi-Z Mic: 200mV

Bridge: 2V

Aux: 13V

Operating Voltage: 120V 60Hz 0.3A
24-28V DC .01A

Dimensions: 12.375" W x 8.25" H x
3.125" D (31.4 cm x 21
cm x 7.9 cm)

Shipping Weight: 7 lbs. (3.2 kg)

Description

The Model 1004 is a five channel monaural solid state mixer/preamplifier. These channels consist of four microphone channels and one auxiliary channel. All four microphone channels have input provisions for low impedance balanced or high impedance unbalanced microphones. The balanced mic inputs use XLR type 3-pin female audio connectors, and unbalanced mic inputs use 1/4 inch phone jacks.

High impedance balanced bridging inputs are also provided on mic channels 1 and 2 as optional input circuits. High impedance unbalanced auxiliary level inputs are also provided on mic channels 3 and 4 as an optional input circuit.

The Auxiliary channel is a high impedance unbalanced RCA input jack. A muting circuit provides

page over music precedence when activated by contact closure across two rear panel screw terminals.

A master level control is provided to adjust the output level of the unit. Three outputs are provided: 1) a high impedance unbalanced high level output to drive amplifiers with an input impedance of 4.7K ohm or greater, 2) a high impedance unbalanced output to drive the microphone input of an amplifier with an input impedance of 500 ohm or greater, and 3) a low impedance balanced output to drive a 100 to 300 ohm microphone input of an amplifier.

The unit may be powered from either 120 Volt 60 Hz or a 24 to 28 Volt D.C. battery. The Model 1004 may be rack mounted by means of the MODEL RPK-6 rack panel kit.

Architect's and Engineer's Specifications

The mixer /preamplifier shall have five input channels. The inputs shall consist of four microphone channels and one auxiliary channel. The microphone inputs shall accommodate either high-impedance or low-impedance microphones. High-impedance balanced bridging inputs shall be provided on mic channels one and two as optional input circuits. High impedance unbalanced auxiliary inputs shall also be provided on input channels three and four.

Music mute terminals shall be provided to allow paging over music. They shall be activated by contact

closure across two rear panel screw terminals. Three outputs shall be provided; 1) high-impedance

unbalanced to drive an amplifier with an impedance 4.7 kohm or greater. 2) high-impedance unbalanced to drive the microphone input of an amplifier of 500 ohm or greater. 3) low-impedance balanced output to drive a 100 to 300 ohm microphone input of an amplifier.

The unit shall measure 12.375" x 8.25" x 3.125" (31.4 cm x 21 cm x 7.9 cm), weigh 7 lbs. (3.2 kg) and operate from a 120V, 60 Hz line or 24 to 28V DC.

The mixer/preamp shall be the University Sound

Model 1004.

Rear Panel/Block Diagram

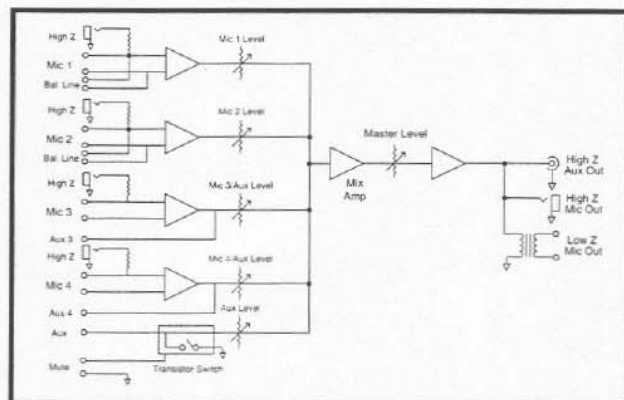
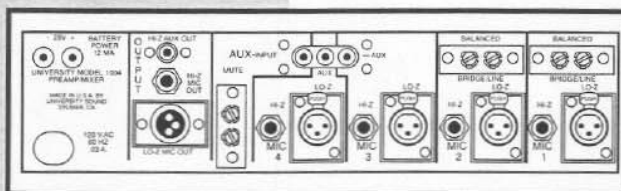

University Sound Inc.

a MARK IV company
13278 Ralston Avenue
Sylmar, CA 91342-7607
FAX (818) 362-3463
PHONE (818) 362-9516

Mark IV Audio Canada
345 Herbert Street
Gananoque, Ontario K7G 2V1
FAX (613) 382-7466
PHONE (613) 382-2141

