

Service manual

HHB Circle 5A

Powered Monitor speaker

with V3 electronics



This manual is subject to change without notice.
Always check with HHB that you are using the latest version.

Also available as an Adobe Acrobat V4 file.

When printing this file, for clear sharp pictures on a black & white laser, it may be necessary to adjust your printer driver's 'Print half tone' settings. If you have a 600dpi printer, setting the half tone to around 45 lines per inch will give a clean sharp image, where as the default - around 60lpi may give a dark image to pictures..

WARNING! DANGER OF ELECTRICAL SHOCK

Opening mains operated equipment like the HHB Circle 5A incurs a risk of electric shock. DO NOT attempt to open this equipment unless you are qualified to do so, have the necessary test equipment and are operating the Circle 5A from an ISOLATED POWER SUPPLY.

Ensure that only the correct mains voltage is applied, as marked on the module.

NEVER OPERATE OR OPEN THIS SPEAKER IN DAMP OR WET CONDITIONS AND NEVER ALLOW IT TO BE USED OUTSIDE. ENSURE THAT ALL POWER AND SIGNAL CABLES ARE IN PERFECT CONDITION AND ARE CORRECTLY FUSED.

IF IN DOUBT, CONTACT HHB IMMEDIATELY BEFORE PROCEEDING.

Contents

- Page 1: The cover and warning
- Page 2: (This) index page
- Page 3: Section 1.0: External arrangement and comments on connectors/controls
- Page 4: Section 2.0:
General arrangement, notes on testing
- Page 5: Section 3.0:
Access to the Circle5A electronic module
- Page 6: Section 4.0:
General inside views of C5A module
- Page 7: Section 4.1
Close-up view of C5A module's circuit boards
- Page 8: Circuit diagram: C5AIPM input board
- Page 9: Circuit diagram: C5APAM's rectifier/PSU/mute circuit
- Page 10: Circuit diagram: C5APAM's active filters
- Page 11: Circuit diagram: C5APAM's power output circuit
- Page 12: Parts list
- Page 13: Fault finding
- Page 14: Modifications and updates

1.0 External details

This is a view of the external controls on the Circle5A.

1.1 Master Volume Control

The function of the Master Volume control is really that of a sensitivity control - to scale down excessive input signals. In a set-up where the signal level is scaled so that set to maximum (fully clockwise) an input of 0.775VdBV, on the loudest peaks, will fully drive the power amplifiers. Since many sources give a signal under normal programme that is significantly greater than 0.775V, it is expected that in most situations the Circle 5A's volume control will be set to about half way i.e. 12 o'clock. This would apply in many studio's where the '+4' signal reference is the maximum. Note: as you will observe from the circuit diagram, the volume control follows the input buffer stage, and the input amplifier will overload and distort if the input signal is excessive *whatever the volume control is set to*.

1.2 Input sockets and selector switch

There are two input connectors: a master input, an isolated XLR following the normal European wiring convention:

- Pin 1 = shield (ground*)
- Pin 2 = Live, hot, + signal
- Pin 3 = Cold, -, return signal

* Pin 1 is connected to the ground of the C5A's electronics. There is no connection from the audio ground to the mains (safety) ground. The metal panel is the only part of the C5A's electronics that is connected to the mains ground.

Also provided is a secondary input: a Phono (Cinch, RCA) connector for unbalanced systems. The centre pin is signal +, and the connector case is the ground. The phono plug's case is connected to the C5a's signal ground, not the mains (safety) ground. Neither input is transformer isolated, and therefore care must be taken to eliminate hum loops.

The selector switch selects which of the two inputs is fed to the input buffer IC.

Connect to EITHER the XLR or the phono, not both.

Only use the mains cable supplied. Replace the mains fuse with the correct type. The Circle5A must be earthed at all times, and is not suitable for use outdoors.



External view of C5A's version 3 panel

2.0 General arrangement

All the signal processing circuitry of the Circle5A amplifier module is arranged on two PCB's - one 'passive' board, the C5AIPM holds the XLR, selector switch, volume control and phono socket. This is connected to the C5APAM (filter/PSU/power amp) board via a 6 way wire loom. There are no user-adjustable parts.

Although mains voltages do not appear on the PCB, but care should be taken when examining and working on the module, since the secondary of the mains transformer (25-0-25 AC) is connected to the bridge rectifiers and smoothing capacitors on the board. These store considerable energy, and are capable of creating a spark many minutes after the C5A's mains power is removed.

The very low level of self noise generated in the circuitry means that, at idle, there is an extremely low level of background noise generated in the circuitry. If the C5A is powered up the front panel power-on LED fitted to the tweeter face plate just above the bass unit will glow green, indicating that the speaker is powered and awaiting a signal. If the power-on LED is illuminated, by definition, the PSU is working, and the two LED's on the C5APAM will be glowing, confirming that the +/- 12V rails are operational.

To minimise power-on and power off 'thumps' appearing at the drive units, a circuit detects the presence of mains 50/60Hz cycles, and should the mains disappear (either because the user has intentionally or unintentionally switched off the speaker or because of mains supply failure) the C5A will revert to muted mode a virtually instantaneously and the audio output circuitry will switch off, and programme will not be heard.

The power-on LED is driven from the rectified regulated supply rail, and is a positive indication that the transformer, rectifiers and smoothing capacitors are functioning correctly.

The bass unit is directly driven from a pair of IC power amplifiers in bridge push-pull mode. The tweeter is driven from one IC.

NOTE CAREFULLY:

DO NOT CONNECT EITHER OF THE BASS OUTPUT TERMINALS TO GROUND SINCE THIS MAY DESTROY ONE OR BOTH BASS POWER IC'S. THIS WILL REQUIRE THE REMOVAL AND REPLACEMENT OF ONE OR MORE POWER IC'S, A DIFFICULT AND EXPENSIVE TASK.

Sec 3.0 Removing the Circle 5A's active module from the cabinet

It is absolutely essential that before removing the module you have the necessary tools, a clear space, and sufficient uninterrupted time to work. Rushing leads to mistakes, and mistakes can be dangerous and impair the excellent performance of your Circle 5A speakers.

An isolated mains PSU is essential for your electrical safety: be sure you never work on equipment directly connected to the mains supply. Ensure that the mains supply is disconnected and removed from the module, and is not reconnected until the module has been fully refitted.

We suggest that you cover your work bench with a soft material to protect the underside of your Circle 5A's from scuffing during removal/replacement of the module. Also be aware that the module is heavy and that once the screws are loosened, it will tend to drop downwards, and that the heavy aluminium panel of the module will readily chip the softer wood of the cabinet, exposing the white MDF board under the black paint. You will need two screwdrivers:

3.1: A 3.0mm cross head screwdriver of the 'Superscrew' or 'Pozidrive' NOT Phillips type. The Superscrew type has 4 thin grooves into which the Superscrew screw driver securely locates. If the Phillips type is used, the screwdriver will 'mash' the heads, and then it may not be possible to remove the module from the cabinet.

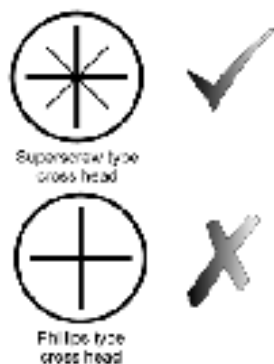

3.2: A larger size (M4, 4mm, No.2) 'Superscrew' or 'Pozidrive' screwdriver.

Section 3.3: Removing the screws

Please follow these instructions exactly. Failure to do so may well destroy your cabinet and/or module.



NB: This photo is of the earlier module, but the screw arrangement is identical

First, using your smaller Superscrew driver, check that the screwdriver makes a positive fit to the screws marked 1,2,3,4. Applying as little force as necessary, unscrew (anti-clockwise) the four corner machine screws in the order 1, 2, 3, 4.

These screws locate in metal inserts trapped in the inside of the cabinet, and the alignment of the module and the cabinet is precise.

Then, using the larger screw driver, remove the screws A, B, C, D, E and, as you loosed screw F, expect the module to drop down. Be ready to catch it!

The module can then be removed a short distance from the cabinet, as the internal connections to the module are on short flexible wires. Be ready to carefully note the colour coding and position of the wires that connect the module to the woofer, tweeter and LED's.

Sec. 4.0 General view of C5A module viewed from the inside

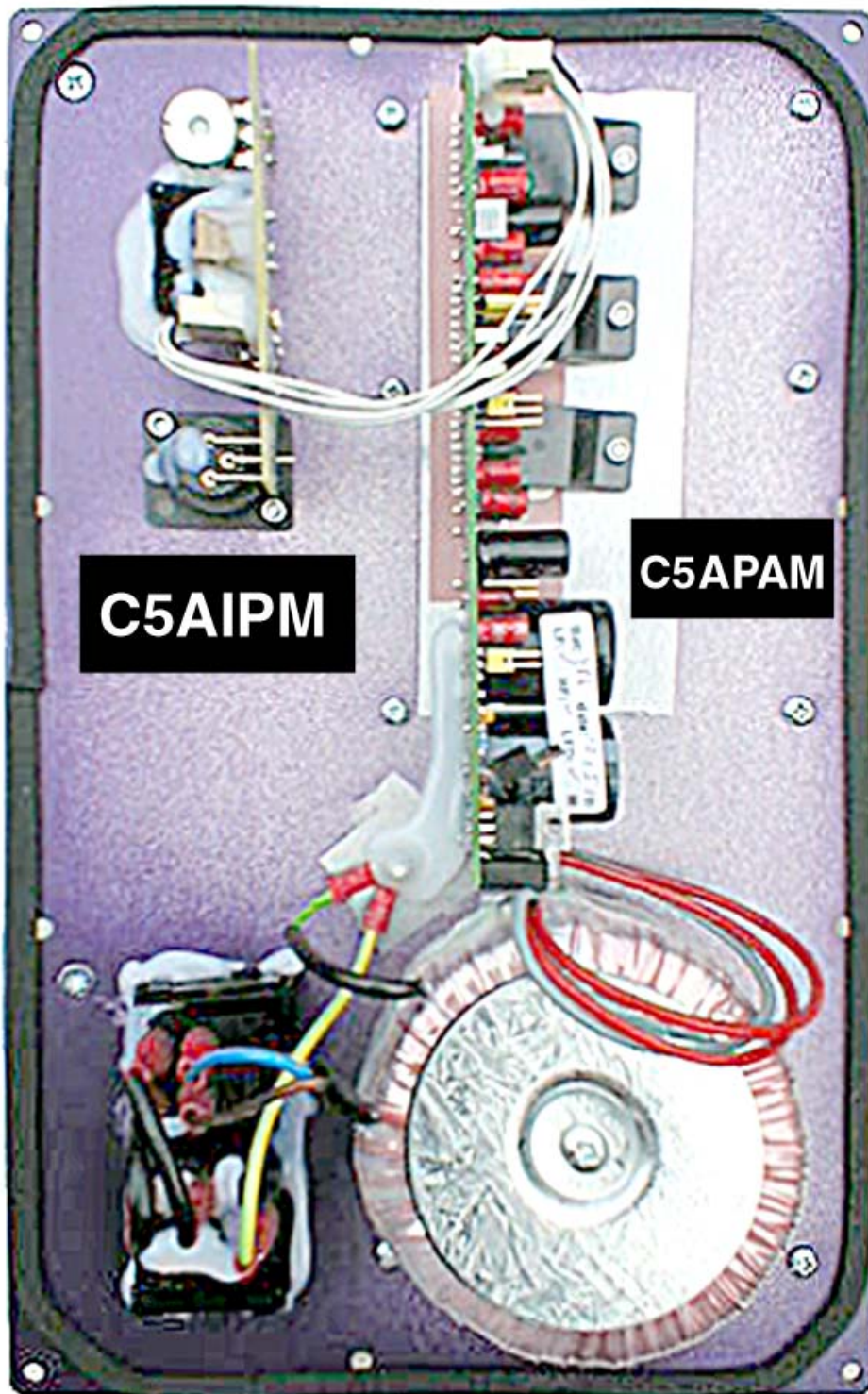

There are four function blocks in the C5A electronic module:

C5AIPM: a small PCB carrying the XLR, phono, volume control and selector switch. This is secured to the panel by the nut of the volume control and the two M3 nylock nuts that secure the XLR socket.

The input signal, once selected by the user switch is sent to the **C5APAM**

MAINS TRANSFORMER:

The mains primary is connected directly to the user's mains off-on switch. The single secondary is connected to the C5APAM. The transformer's mains operating voltage is not adjustable; various voltages are available for different market conditions.

Section 4.1 Close-up views of inside of C5A module

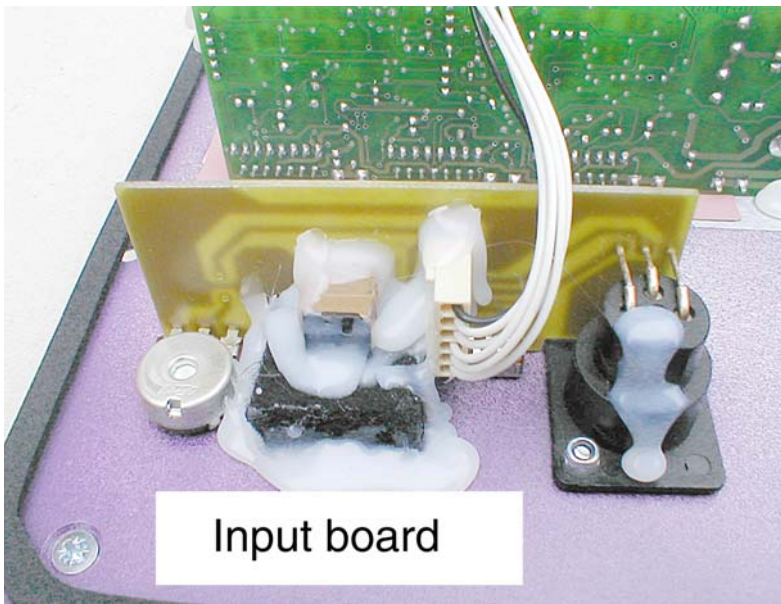

C5AIPM:
note air holes are sealed with hot glue.

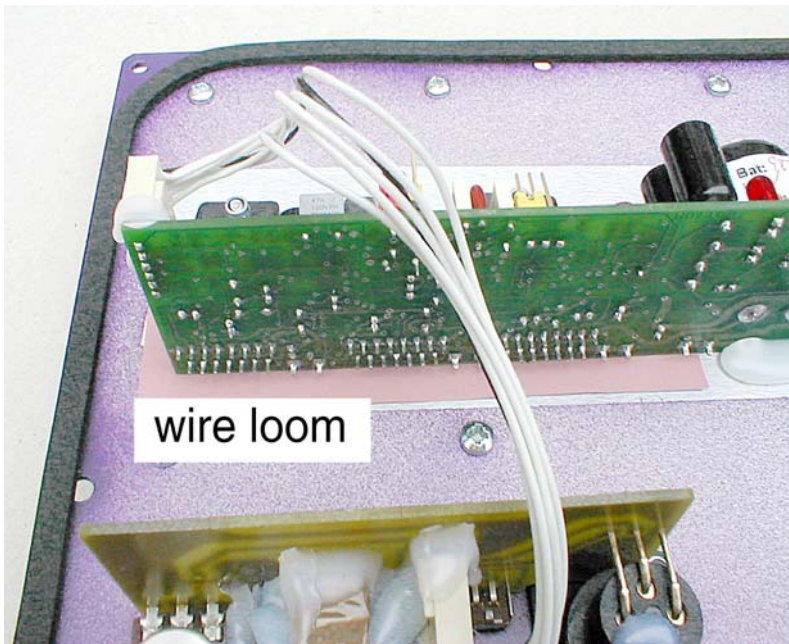

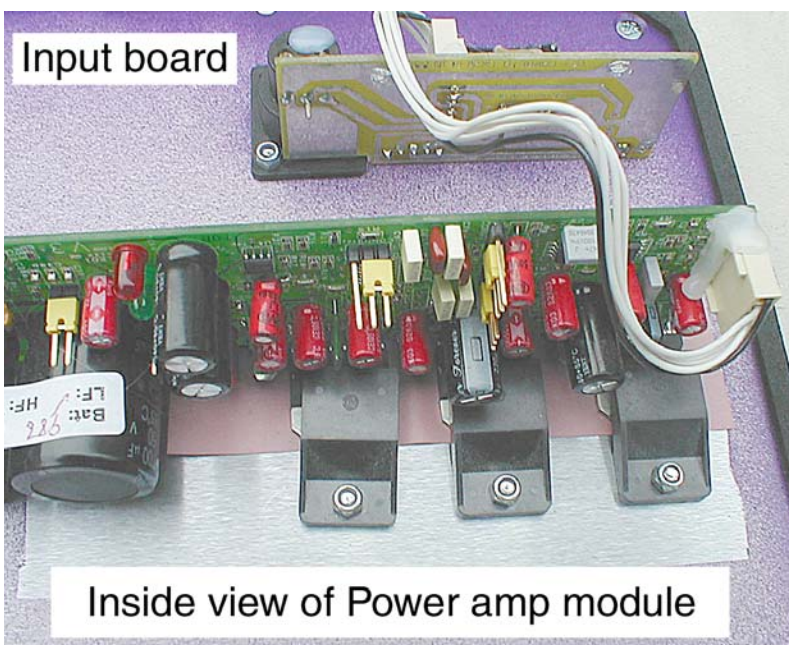

Wire loom connecting *C5AIPM* to *C5APAM*

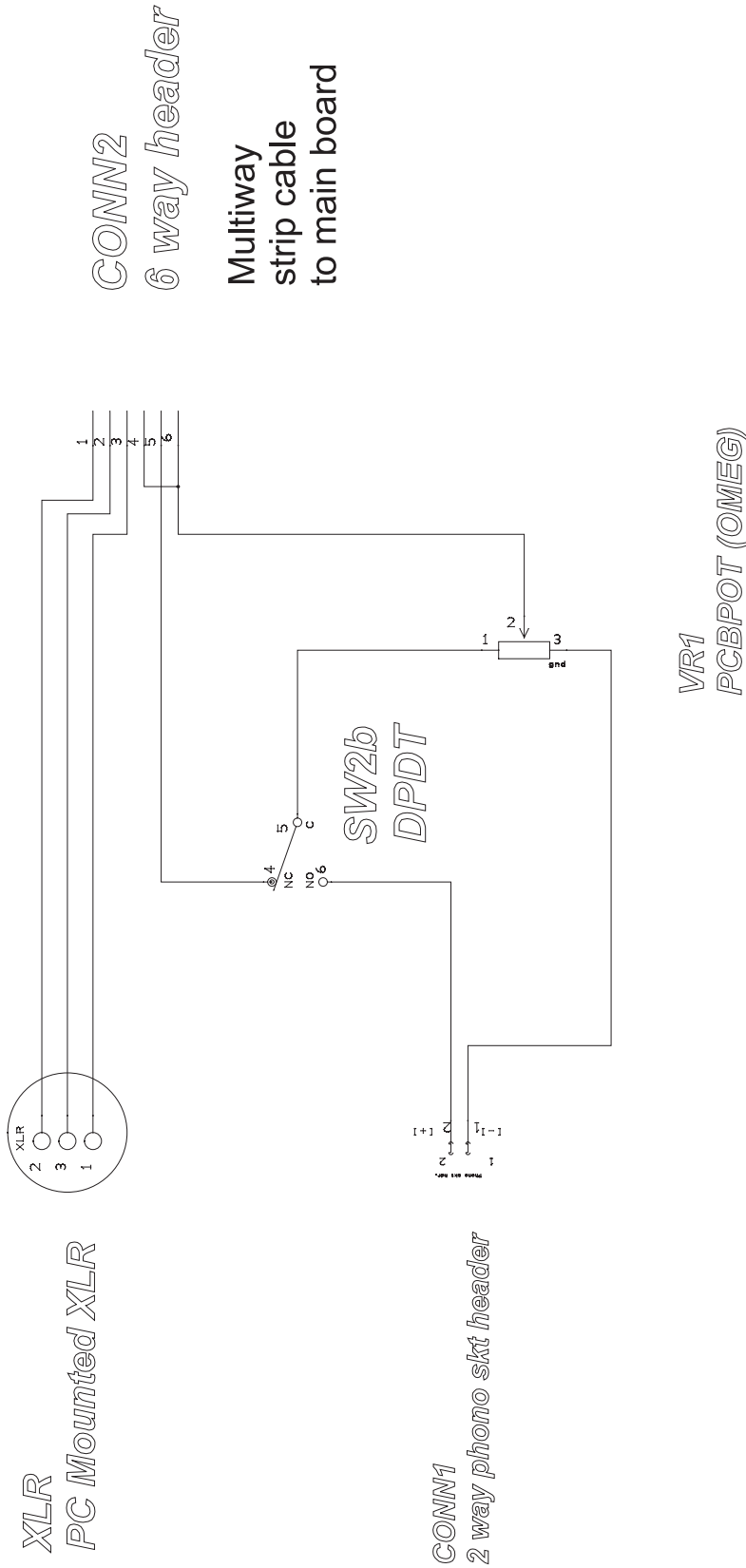

C5APAM

ALL THESE COMPONENTS ARE TO BE FOUND ON THE C5APAM

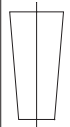

| | | | | | | | |
|------------|--|--|--|--|---|---|------------|
| | | | | |  |  | SCH-1390 |
| | | | | | C5A/3 Input board | | |
| | | | | | (C) Harbeth Audio Ltd | | 05.02.2002 |
| OTL1 A4 | | | | | | | |

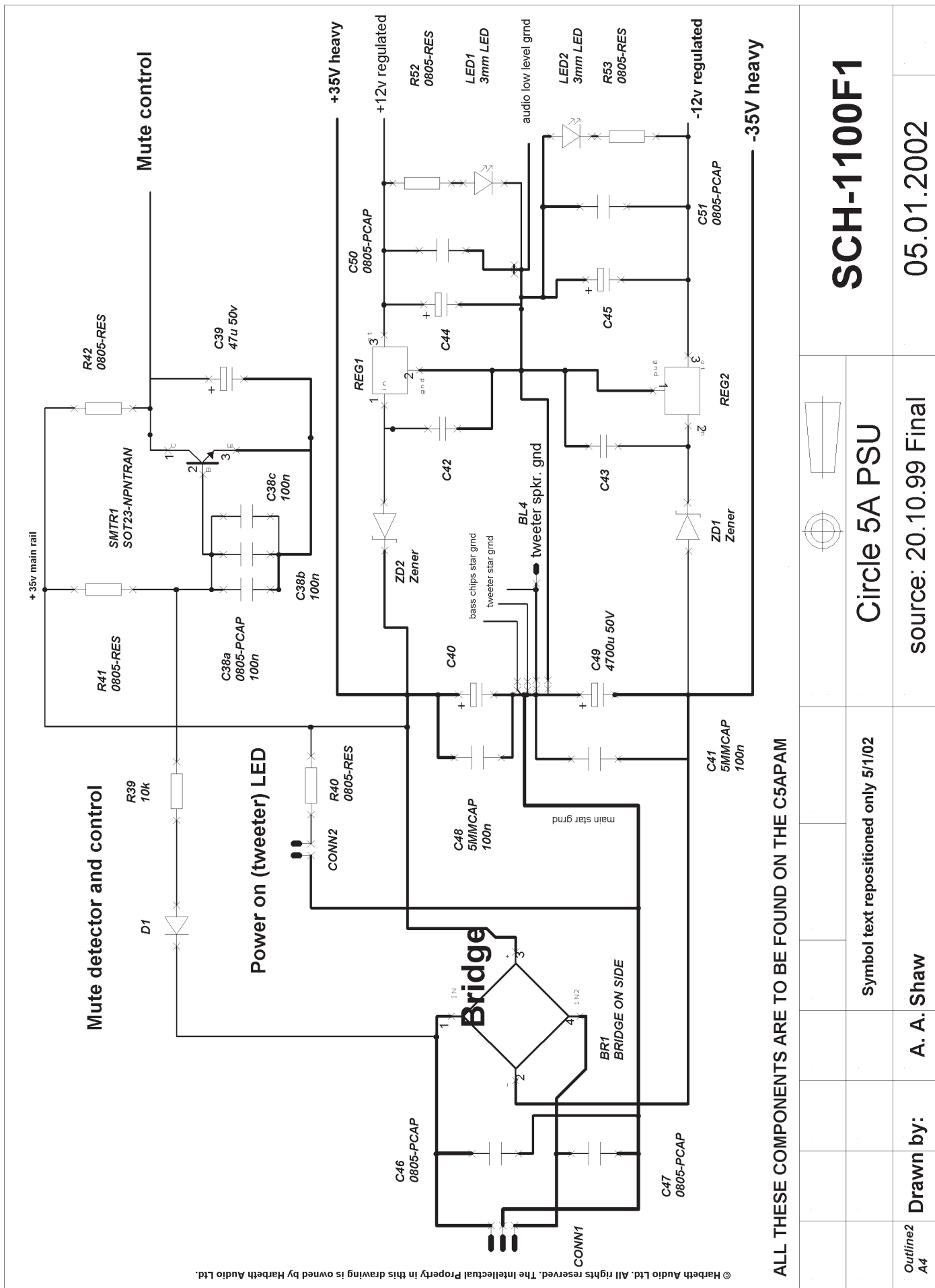

© Harbeth Audio Ltd. All rights reserved. The Intellectual Property in this drawing is owned by Harbeth Audio Ltd.

ALL THESE COMPONENTS ARE TO BE FOUND ON THE C5APAM

| | | |
|------------------------|-----------------------------|---|
| | | <h1>SCH-1100F1</h1> |
| | <h2>Circle 5A PSU</h2> | <p>Symbol text repositioned only 5/1/02</p> |
| <p>Outline2 A4</p> | <p>Drawn by: A. A. Shaw</p> | <p>source: 20.10.99 Final</p> |
| | | <p>05.01.2002</p> |

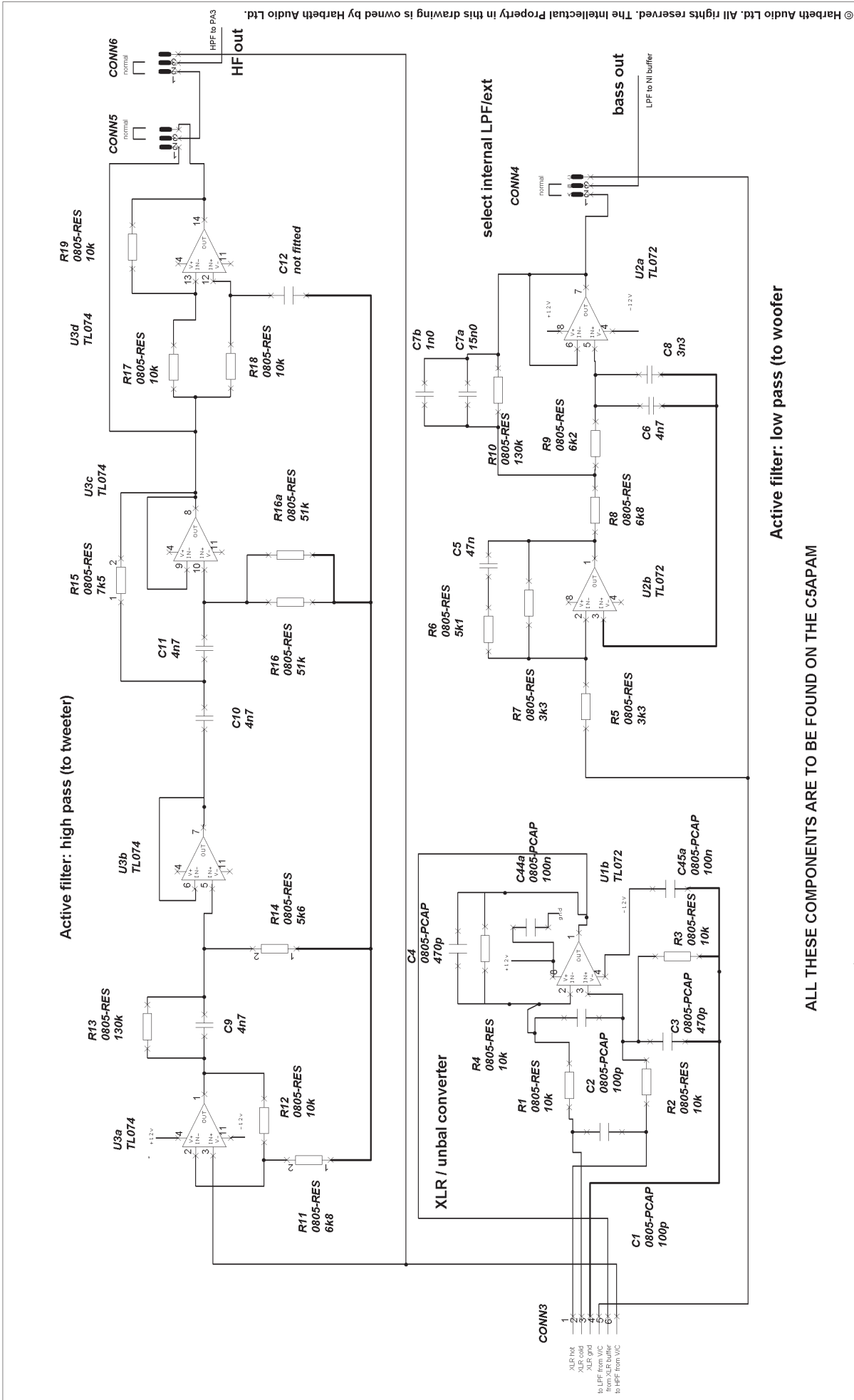

| | | |
|-----------|-------------------------------|--------------------------------------|
| | SCH-1300H1 | |
| | C5A/3 Filter/input pcb | |
| | A. A. Shaw | Symbol text repositioned only 5/1/02 |
| Drawn by: | A. A. Shaw | source: 20.10.99 Final |
| UNUSED | | Outline3 |

UNUSED



U1a
TL072

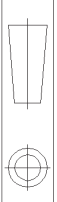
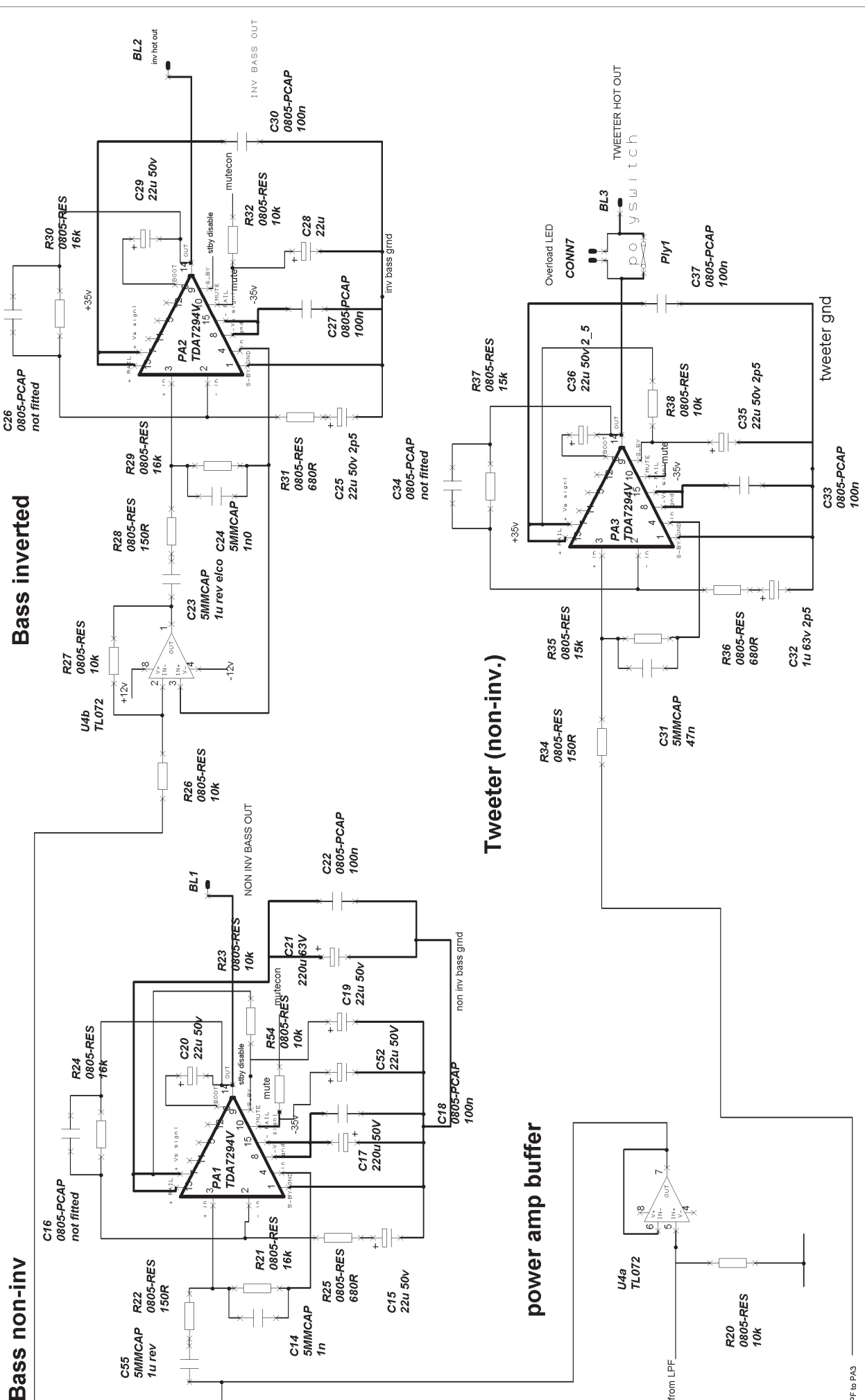

SCH-1200L1

C5A Mk3 Power amp

source: 23.8.99

05.01.2002

